

ISTANBUL BILGI UNIVERSITY
INSTITUTE OF SOCIAL SCIENCES
CLINICAL PSYCHOLOGY MASTER'S DEGREE PROGRAM

AN INVESTIGATION OF RELIABILITY AND VALIDITY OF THE GUILT
AND SHAME PRONENESS SCALE WITH A TURKISH SAMPLE

Didem Topçu
115627016

Alev ÇAVDAR SİDERİS, FACULTY MEMBER, PhD

İSTANBUL
2019

An Investigation of Reliability and Validity of the Guilt and Shame Proneness Scale with a
Turkish Sample

Suçluluk ve Utanç Eğilimi Ölçeğinin Güvenilirliğinin ve Geçerliliğinin Türk Örneğinde
İncelenmesi

Didem Topçu

115627016

Tez Danışmanı: Dr. Öğr. Üyesi Alev Çavdar Sideris
İstanbul Bilgi Üniversitesi

İkinci Tez Danışmanı: Dr. Öğr. Üyesi Sibel Halfon
İstanbul Bilgi Üniversitesi

Jüri Üyesi: Dr. Öğretim Üyesi Yasemin Sohtorik İlkmen
Yeditepe Üniversitesi

Tezin Onaylandığı Tarih: 18.01.2019

Toplam Sayfa Sayısı: 82

Anahtar Kelimeler (Türkçe)

- 1) Suçluluk
- 2) Utanç
- 3) Suçluluk eğilimi
- 4) Utanç eğilimi
- 5) Ahlaki duygular
- 6) Suçluluk ve Utanç Eğilimi Ölçeği

Anahtar Kelimeler (İngilizce)

- 1) Guilt
- 2) Shame
- 3) Guilt Proneness
- 4) Shame Proneness
- 5) Moral Emotions
- 6) Guilt and Shame Proneness Scale

ACKNOWLEDGEMENTS

I would like to begin with expressing my gratitude to my thesis advisor Alev avdar Sideris for her guidance, support, and assistance in every step of my research process. I decided the subject of my thesis with her suggestion, hence this research process became an opportunity for me to contemplate on the concept of shame and guilt more deeply, which would also help me in my clinical practice, I believe.

I would like to thank Zeynep atay, Diane Sunar, Tuęçe Tokuş, Derya Őendil for their valuable feedback and contributions in the translation process of the scale to Turkish.

I feel grateful to all of my friends, especially Sena Karşlıoęlu, Selma oban, Funda Sancar, Burcu Buęan, Mge Ekerim, Sercan Aydın, Gizem Kkuner, and Yusuf Atabay for the support they provided during the writing process of my thesis.

Lastly, I would like to express my deepest gratitude to my fianc Kaan Yıldıırım for his patience, sympathy, and support throughout this process. His presence made the whole process easier for me.

TABLE OF CONTENTS

Title Page.....	i
Approval.....	ii
ACKNOWLEDGEMENTS.....	iii
TABLE OF CONTENTS.....	iv
List of Tables.....	vii
List of Figures.....	vii
List of Appendices.....	vii
Abstract.....	viii
Özet.....	ix
INTRODUCTION.....	1
1.1. CONCEPTUALIZING SHAME AND GUILT.....	1
1.1.1. How Do Shame and Guilt Differ?.....	2
1.1.1.1. Context: Public versus Private.....	2
1.1.1.2. Target of Negative Evaluation: Self versus Behavior.....	3
1.1.1.3. Action Tendencies: Reperation versus Avoidance.....	4
1.2. SHAME AND GUILT AS BASIC EMOTIONS.....	5
1.3. SHAME AND GUILT AS MORAL EMOTIONS.....	6
1.3.1. Shame as Maladaptive and Guilt as Adaptive Emotions.....	7
1.3.2. Controversial Findings on Guilt as an Adaptive Emotion: Is Guilt a Multidimensional Construct?.....	9

1.4. PSYCHOANALYTIC CONCEPTUALIZATIONS OF SHAME AND GUILT.....	12
1.4.1. Freudian Accounts on Guilt and Shame.....	12
1.4.2. Developmental Ego Psychology and Object Relational Perspectives.....	13
1.4.3. Self Psychology.....	15
1.4.4. Differentiating Shame and Guilt from Psychoanalytic Perspective.....	16
1.5. MEASUREMENT OF GUILT AND SHAME PRONENESS.....	17
1.5.1. Checklist Measures.....	18
1.5.2. Scenario Measures.....	19
1.5.3. The Guilt and Shame Proneness Scale (GASP).....	20
1.6. PRESENT STUDY.....	22
METHOD.....	22
2.1. PARTICIPANTS.....	22
2.2. INSTRUMENTS.....	24
2.2.1. Informed Consent Form.....	24
2.2.2. Demographic Information Form.....	24
2.2.3. Guilt and Shame Proneness Scale (GASP).....	25
2.2.4. Moral Foundations Questionnaire.....	26
2.2.5. Big Five Inventory.....	27
2.2.6. Buss-Warren Aggression Questionnaire.....	27

2.3. PROCEDURE.....	28
RESULTS.....	29
3.1. FACTOR STRUCTURE OF GASP.....	29
3.1.1. Confirmatory Analysis and Reliability of The Original Factor Structure.....	29
3.1.2. Exploratory Analyses with the Turkish Sample.....	30
3.1.3. Confirmatory Analyses with the Turkish Sample.....	33
3.2. RELIABILITY OF GASP SUBSCALES.....	39
3.3. CONSTRUCT VALIDITY OF THE GASP SUBSCALES.....	40
3.3.1. Correlations among GASP Subscales.....	41
3.3.2. Correlations between GASP Subscales and Other Measures.....	41
3.4. ADDITIONAL FINDINGS.....	43
DISCUSSION.....	44
4.1 LIMITATIONS AND SUGGESTIONS FOR FUTURE RESEARCH.....	51
CONCLUSION.....	52
References.....	53
APPENDICES.....	66

List of Tables

Table 1. The Descriptive Statistics of GASP Items.....	30
Table 2. Pattern Matrix for Exploratory Factor Analysis.....	31
Table 3. Changes in the Initial Model of Factor Structure.....	33
Table 4. Summary of EFA and CFA Findings.....	36
Table 5. Descriptive Statistics for Study Variables.....	40
Table 6. Subscale Correlations of GASP.....	41
Table 7. Bivariate Correlations of GASP with Other Study Variables.....	43

List of Figures

Figure 1. Confirmatory Factor Analysis of the Initial Model.....	34
Figure 2. Confirmatory Factor Analysis of the Modified Model.....	35

List of Appendices

APPENDIX A: Informed Consent Form.....	66
APPENDIX B: Guilt and Shame Proneness Scale (GASP).....	67
APPENDIX C: Guilt and Shame Proneness Scale (Turkish Form).....	70
APPENDIX D: Moral Foundations Questionnaire.....	73
APPENDIX E: Buss-Warren Aggression Questionnaire.....	76
APPENDIX F: Big Five Inventory.....	79
APPENDIX G: Demographic Information Form.....	81

Abstract

The aim of this study was to adapt Guilt and Shame Proneness Scale to Turkish and determine its psychometric properties. To this aim, the original scale was translated to Turkish, and back translation was performed. Revisions were made in accordance with the opinions of experts on the clarity of items and congruity of the language to the culture, and the Turkish version of the scale reached its final form. In order to test the factor structure, and reliability and validity of the Turkish version of the scale, participants were asked to fill out Turkish version of the GASP, Moral Foundations Questionnaire, Buss-Warren Aggression Questionnaire, Big Five Inventory, and a demographic information form. The data was collected online through convenient sampling method. Of the 401 individuals participated in the study, the data of 383 participants was suitable for analyses. The data was randomly split approximately in two halves, one of which was used for exploratory factor analysis, and the other for the confirmatory factor analysis. Based on the exploratory and confirmatory factor analyses, 6 items were not advised to be included in the Turkish version of the scale. Shame NSE and shame withdraw subscales of the scale remained only two items in each, and the reliability scores of these subscales were found to be low. Thus, the results of this study failed to provide evidence for shame-related subscales of the Turkish version of GASP to be valid and reliable measures. Potential methodological, cultural, and theoretical explanations for the findings were discussed; and future directions for further research were presented.

Keywords: guilt, shame, shame proneness, guilt proneness, moral emotions, Guilt and Shame Proneness Scale

Özet

Bu çalışmanın amacı Suçluluk ve Utanç Eğilimi Ölçeğini Türkçe'ye uyarlamak ve ölçeğin psikometrik özelliklerini belirlemektir. Bu amaçla ölçeğin orijinal formu Türkçe'ye çevrilmiş ve Türkçeye çevrilmiş hali tekrardan İngilizceye çevrilerek ölçeğin orijinal hali ile karşılaştırılmıştır. Uzmanların ölçeğin maddelerinin anlaşılabilirliği, kullanılan dilin kültüre uygunluğu hakkındaki görüşleri doğrultusunda gerekli düzeltmeler yapılmış ve ölçeğin Türkçe formu böylelikle son haline kavuşmuştur. Ölçeğin faktör yapısı, güvenilirliği ve geçerliliğini test etmek amacı ile katılımcılardan Suçluluk ve Utanç Eğilimi Ölçeği, Ahlaki Temeller Ölçeği, Buss-Warren Agresyon Ölçeği, Beş Faktörlü Kişilik Envanteri ve demografik bilgi formunu doldurmaları istenmiştir. Veriler internet üzerinden, kolayda örnekleme yöntemi ile elde edilmiştir. Araştırmaya katılan 401 kişiden 383 katılımcının verileri analiz için uygun bulunmuştur. Elde edilen verilerin rastgele seçilen ve yaklaşık olarak tüm verilerin yarısına tekabül eden bir kısmı keşfedici faktör analizi için, diğer kısmı ise doğrulayıcı faktör analizi için kullanılmıştır. Keşfedici ve doğrulayıcı faktör analizlerinin doğrultusunda 6 maddenin ölçeğin Türkçe versiyonuna dahil edilmemesi önerilmiştir. Utanç alt ölçeklerinin her birinde sadece iki madde kalmıştır ve bu ölçeklerin güvenilirlik değerleri düşük bulunmuştur. Çalışmanın bulguları ölçeğin Türkçe formundaki utançla ilişkili alt ölçeklerin geçerli ve güvenilir olduğuna ilişkin kanıt sunmakta başarısız olmuştur. Bulgulara yönelik olası yöntemsel, kültürel ve teorik açıklamalar tartışılmış ve ileriki çalışmalar için öneriler sunulmuştur.

Anahtar kelimeler: suçluluk, utanç, suçluluk eğilimi, utanç eğilimi, ahlaki duygular, Suçluluk ve Utanç Eğilimi Ölçeği

INTRODUCTION

1.1.CONCEPTUALIZING SHAME AND GUILT

Shame and guilt, along with embarrassment and pride, are considered as self-conscious emotions in the literature. This categorization implies that in order for shame and guilt to be evoked, a self-evaluative process through which the self reflects on itself is required (Tangney, Stuewig & Mashek, 2007). In Merriam-Webster's online dictionary shame is described as "a painful emotion elicited by the awareness of guilt, shortcoming, or impropriety" ("Shame", n.d.), while guilt is described as "a feeling of deserving blame for offenses" ("Guilt", n.d.).

Apart from being both self-conscious emotions, the fact that guilt and shame have certain characteristics in common, and also that experiences of these two emotions often coexist in real life (Lewis, 1971), makes it difficult to differentiate them from one another for laypersons; thus, leading to the use of the two terms synonymously (Carni, Petrocchi, Miglio, Mancini & Couyoumdjian, 2013). It is stated that not only layperson but also scholars and experts have neglected the distinctiveness of these two emotions (Tangney & Dearing, 2002). They are both negatively valenced and painful emotions, entailing feelings of distress against personal transgressions or faults (Tangney & Dearing, 2002). In the contemporary literature, scholars seem to have reached a consensus on the distinctiveness of shame and guilt; however, how they differ remains an issue still debated by scholars (Cohen, Wolf, Panter & Insko, 2011).

Above descriptions and conceptual confusion pertain to the shame and guilt as affective states. However, the same confusion seems to prevail in defining those emotions as dispositional tendencies and in differentiating them. Proneness to shame and guilt was conceptualized as individual differences in the tendency to experience shame and guilt as reactions to transgressions on behavioral, affective and cognitive levels (Tangney & Dearing, 2002). Tignor and Colvin (2016) pointed out that although not consistent; there is sometimes a terminological distinction between the tendency to experience, and tendency to anticipate these

emotions in the literature, former of which is referred as trait shame or guilt, and the latter of which is referred as proneness to shame and guilt. Wolf, Cohen, Panter, and Insko (2010) also pointed out the distinction in their conceptualization between the phenomenology of affective experience of these emotions and proneness to shame and guilt, by stating that proneness to shame and guilt does not equate with high frequencies of actually experiencing those emotions. Instead, they suggested that those whose likelihood of anticipating to feel shame and guilt are more likely to refrain themselves from the situations that might elicit those emotions.

1.1.1. How Do Shame and Guilt Differ?

There are various approaches, and thus criteria, for distinguishing shame and guilt. The most encompassing dimensions, which are the context, the target of the negative evaluation, and the action tendencies, will be summarized below.

1.1.1.1. Context: Public versus Private

From an anthropological perspective, it has been argued that shame and guilt differ in the type of situations or events that give rise to them (Benedict, 1946). According to this view, shame is more likely to be experienced when misdeeds or transgressions are publicly exposed, while guilt is more related to the private experience of behaving in a way that breaches one's conscience. In support for this view, publicly exposed transgressions were found to be more associated with shame (Combs, Campbell, Jackson, & Smith, 2010; Smith, Webster, Parrott, & Eyre, 2002). It has been argued that for shame, one's fear of negative evaluations of others who witnessed the fault or transgression mainly elicits the emotion (Ausubel, 1955); on the other hand, for guilt, what evokes the emotion is one's own negative self-evaluation (Combs et al., 2010).

Validity of differentiating shame and guilt on the basis of public versus private distinction has been challenged by some researchers (Tangney, Miller,

Flicker, & Barlow, 1996; Tangney & Dearing, 2002). Based on empirical findings, Tangney and her colleagues (1996) proposed that one might experience both shame and guilt either as a private context or in the presence of others. Furthermore, Martenz (2005) postulated that not necessarily a real existence but a fantasized or imaginary presence of others might be a feature that distinguishes shame from guilt. Although some researchers argue against the use of public versus private distinction as a distinguishing criterion, they agree that although both emotions occur in a social context, shame may involve more the feeling of being seen and exposed whether it be actual or imagined (Tangney & Dearing, 2002; Tracy, Robins & Tangney, 2007). Moreover, recent research suggested that measuring guilt proneness and shame proneness with publicly exposed transgressions and private transgressions respectively has merit in differentiating the two emotions better (Cohen et al. 2011; Wolf et al. 2010).

1.1.1.2. Target of Negative Evaluation: Self versus Behavior

Another criterion relies on whether the self confines its negative evaluations to itself or its behavior against transgression (Lewis, 1971; Tangney & Dearing, 2002; Tracy & Robins, 2004). According to this perspective, when a person ascribes the blame to his self in case of transgression or wrongdoing, occurring emotion would be shame. On the other hand, if the person attributes the fault to an unstable action over which he has control, instead of making global ascriptions to the self, guilt is likely to occur.

According to Lewis (1971), phenomenological experiences of shame and guilt also differ due to the object of self-evaluative process on the committed transgression, (as the global self versus a specific act). Particularly, compared to the psychological pain associated with guilt, shame induced pain is more devastating (Lewis, 1971). According to this model, construing the self as the cause of the wrongdoing explains why affective experience of shame is predominated by the feelings of disparagement and sense of powerlessness, while remorse and regret accompanies guilt. Furthermore, attributing the blame to a

behavior implies the possibility that recurrence of that behavior might be avoided in the future; therefore, a person experiencing guilt can focus on the negative effects of his behavior and orient himself towards repairing the damage he caused instead of taking defensive maneuvers to protect his exposed self as in the case of shame (Tracy et al., 2007).

Carni et al. (2013) opposed the self versus behavior distinction by suggesting that through generalization of the blame on the behavior to the more general regard of the blame on the self; one can feel guilty as well. In a similar manner, they suggested that shame does not always include the negative evaluation of the self in a global manner and pointed out the possibility of negative self-view, pertaining only to certain aspect of the self. Although its validity has been questioned, self versus behavior distinction is considered as a widely accepted criterion in the literature (Gausel, 2012).

1.1.1.3. Action Tendencies: Reperation versus Avoidance

One assumption derived from Lewis's conceptualization (1971) is that shame and guilt can also be differentiated in terms of motivations and behaviors that are elicited by them (Tangney & Dearing, 2002). Indeed, research about behavioral correlates of shame and guilt demonstrates that the two emotions lead to behavioral tendencies that are in reverse direction to each other (Ketelaar & Au, 2003; Sheikh, & Janoff-Bulman, 2010). Repair-oriented action tendencies such as making amends, apologizing, and compensating for the wrongdoing have been found to be associated with guilt (Howell, Turowski, & Buro, 2012), while shame was found to be more closely associated with avoidance behaviors and reactions, such as hostility and self-defensiveness (Tangney & Dearing, 2002). Based on these findings, guilt is characterized as a more adaptive emotion than shame.

However there exists considerable research demonstrating that shame is also associated with reparative and prosocial behaviors (Gausel & Leach, 2011), as well as motivation to restore a positive self evaluation rather than defending it against further damage (de Hooge, Zeelenberg, & Breugelmans, 2010). De

Hooge, Zeelenberg, and Breugelmans (2011) suggest that shame signals that the goal of maintaining a positive self-view is threatened, and both approach and avoidance behaviors can be motivated to restore the threatened self, depending on the environmental factors that determine the opportunities for restoring the self. Similarly, guilt has also been found to be associated with self-punishing behaviors that do not serve adaptive purposes (Inbar, Pizarro, Gilovich, & Ariely, 2013). Based on these controversial findings some argue against differentiating shame and guilt in terms of their behavioral correlates (Miceli & Castelfranchi, 2018). In fact, based on their research findings Cohen et al. (2011) postulated that behavioral tendencies and emotional dispositions are two distinct constructs and should not be confounded.

1.2. SHAME AND GUILT AS BASIC EMOTIONS

Basic emotions are described as those emotions that can be distinguished from one another, and those that evolved by serving adaptive purposes in respect to goals (Ekman & Cordaro, 2011). Different opinions exist regarding consideration of guilt and shame as basic emotions in the literature depending on which set of characteristics are considered as defining basic emotions. Distinctive universals in signals (such as distinctive facial expressions) and antecedent events, presence in other primates, distinctive physiology and subjective experience, unbidden occurrence, brief duration of the experience with a quick onset are listed as the characteristics of basic emotions by Ekman and Cordaro (2011). They view shame and guilt as possessing most of the characteristics a basic emotion should have; however, they noted both shame and guilt lack having a signal, distinct from that of the family of sadness, and that in order for shame and guilt to be considered as basic emotions, additional evidence from cross-cultural studies are needed.

Tracy, Robins, and Tangney (2007) claimed that self-conscious emotions are distinct from basic emotions in certain aspects. They stated that self-awareness is a prerequisite for self-conscious emotions, and thus they are cognitively more

complex emotions than basic emotions. They also stated that compared to basic emotions they appear later in the development and while basic emotions serve the adaptive function of attaining goals related to survival, self-conscious emotions facilitate attaining social goals. Lastly, they indicated self-conscious emotions lack universally recognizable facial expressions, although distinct posture of body and head along with facial expression (lowering of the eyes and head) is identified for shame (Keltner & Harker, 1988; Tomkins, 1963).

By citing Kemeny, Gruenewald, and Dickerson (2004) who suggested considering emotions on a continuum, one end of which represents basic emotions, and other end of which represents self-conscious emotions, Tracy et al. (2007) postulate that an emotion may vary in the extent to which it represents these two categories of emotion. They argue that while shame is a good exemplar of basic emotions as well as self-conscious emotions, guilt represents a bad exemplar of basic emotions.

Similar to Tracy et al.'s (2007) conceptualization, on the basis of findings of neurobiological research showing that basic emotions and guilt lead to activation both in distinct (Michl et al., 2012) and overlapping neural circuits (Blair, Budhani, Colledge, & Scott, 2005), Malti (2016) advocated considering guilt as a more complex emotion though rooted in basic emotions. On the other hand, in the model presented by Ellison (2005), shame is considered as a basic emotion, which is evoked by the perception of being devalued, whereas guilt is conceptualized as not an emotion but rather as a condition to which any mixture of affects and cognitions may become associated.

1.3. SHAME AND GUILT AS MORAL EMOTIONS

The literature on shame and guilt is accumulated mostly within the field of social psychology, around their functions as moral emotions. Moral emotions have a significant influence in our moral choices and behaviors. When contemplating on or performing a certain act, moral emotions as a part of the self-reflective process provide prospective information and retrospective feedback

regarding the acceptability of that behavior; which further elicits punishment or reinforcement of that behavior (Tangney et al., 2007). In other words, shame and guilt as moral emotions provide negative anticipatory and consequential feedback, thus serve to withhold people from wrongdoings. In this respect, moral emotions can be considered as motivational forces that promote adherence to moral standards one holds, and consequently ward off social rejection (Kroll & Egan, 2004).

However, in terms of the degree to which the aforementioned feedback function regarding the morality, shame and guilt differ. First, guilt is more associated with the situations that involve violation of a moral standard or value, while shame is also likely to be experienced in nonmoral contexts as a response to one's shortcomings, inadequacies, as well as in moral ones (Lewis, 1971, Smith et al., 2002). While empirical research provides support for the moral and adaptive functions of the guilt repeatedly, there is lack of the evidence regarding the presumed adaptive functions of shame (Tangney et al., 2007). Rather, shame is described in the literature as possessing a maladaptive nature.

1.3.1. Shame as Maladaptive and Guilt as Adaptive Emotions

Hoffman (1982) ascribes an important role to the feeling of guilt in the development of other-oriented empathy. From an interpersonal perspective, guilt emanates from the fear of losing a relationship with loved ones and it promotes repairing the harm done to the relationship by confessing one's fault, apologizing for the mistake etc. (Carni et al., 2013), thus it serves fostering social relationships through generating concern for well-being for others (Tangney, 1991; Baumeister, Stillwell, & Heatherton, 1994). In line with the reparative function ascribed to guilt, empirical studies show that guilt is positively associated with prosocial cooperative behavior (De Hooge, Zeelenberg, & Breugelmans, 2007; Ketelaar & Au, 2003; Roberts, Strayer, & Denham, 2014), perspective taking, and empathic responsiveness (Leith & Baumeister, 1998; Tangney, 1991; Yang, Yang, & Chiou, 2010). In contrast, generally no association has been found between guilt

free shame and empathic concern, while only occasionally negative associations have been reported between shame and perspective taking (Joireman, 2004; Tangney & Dearing, 2002).

Research also shows a consistent pattern of inverse relationship between guilt proneness and delinquency. Cohen et al. (2011) found that guilt prone adults are less likely to make unethical business decisions, and to deceive another person for financial gain. In a longitudinal study, Stuewig, Tangney, and Kendall (2015) reported differential effects of shame and guilt proneness on deviant behavior. Findings of their study revealed that young adults who are assessed as more prone to experience guilt in their childhood are less likely to engage in risky sexual behavior and to get involved in crimes, while shame proneness measured in childhood is shown to be posing a risk for engaging in deviant behavior by young adulthood.

Proneness to shame and guilt has also been found to have different effects on likelihood of experiencing anger and coping with that anger. Lewis (1971) observed that clients' shame experiences are followed by anger reactions in psychotherapy sessions. In support of Lewis's observation, shame prone individuals are found to be more likely to experience anger and once experience anger; they are more likely to deal with that in destructive ways such as engaging in direct, indirect and displaced aggression (Tangney & Dearing, 2002). Shame induced anger or fury is construed as a defensive maneuver to switch from a position, where the self is evaluated as powerless and inferior, to another position where the sense of agency and control is regained. In fact, in the study conducted by Ahmed and Braithwaite (2004), self-initiated bullying among children was found to be positively related to unacknowledged shame feelings, which are converted into anger and blame, and displaced onto others. In the same study, a positive relationship -though not statistically significant- between shame proneness and bullying was reported. Research conducted by Stuewig, Tangney, Heigel, Harty and McCloskey (2010) revealed that proneness to shame and aggression are linked to each other indirectly through externalization of blame; that is, shame proneness is associated with higher levels of externalization of

blame, hence is positively related to aggression. On the other hand, they found that guilt prone individuals are less likely to engage in aggressive behaviors through low levels of externalization of blame and more empathy. Furthermore, guilt proneness is found to be positively correlated to expression of anger in nonhostile and constructive ways (Tangney & Dearing, 2002).

As to the adaptive or maladaptive functions of guilt and shame, their association with psychological problems offer further indications. Shame proneness has been found to be linked to various psychological symptoms, while guilt proneness has found to be unrelated to psychological problems when its shared variance with shame proneness was controlled. Empirical research indicates a positive association between shame proneness and wide range of psychological problems, such as depression, somatization, post-traumatic stress disorder (PTSD), eating disorder, and obsessive-compulsive disorder, psychoticism, and anxiety (Fontaine, Luyten, De Boeck & Corvelyn, 2001; Murray, Waller, & Legg, 2000; Orth, Berking, & Burkhardt, 2006; Pineles, Street, & Koenen, 2006; Tangney, Wagner, Fletcher, & Gramzow, 1992).

1.3.2. Controversial Findings on Guilt as an Adaptive Emotion: Is Guilt a Multidimensional Construct?

Although based on research findings as discussed in the previous section a consensus seems to be reached on the maladaptive nature of shame, there exist considerable research findings that question viewing guilt as a solely adaptive emotion. To illustrate, not only shame but also guilt at state level has been found to be positively associated with negative perfectionism (Fedewa, Burns, & Gomez, 2005). Significant correlations between guilt and a wide array of psychological symptoms such as somatization, interpersonal sensitivity, hostility, anxiety, psychoticism (Harder, Cutler, & Rockart, 1992) and depression (Şahin & Şahin, 1992) have been reported; and these associations remained significant even when the shared variance with shame was removed. Other studies suggested a

positive relationship between eating disorders and proneness to guilt (Dunn & Ondercin, 1981; Fairburn & Cooper, 1984).

Embracing different conceptualization of guilt and operationalizing it accordingly, can explain the contradictory findings regarding the adaptiveness of guilt in the aforementioned studies. In fact, in their meta-analytic investigation, Tignor and Colvin (2016) found that the format of the questionnaires that were used to measure proneness to guilt (checklist, scenario-based questionnaires and combination of the two types of questionnaires) was the moderator of the relationship between guilt proneness and pro-social orientation. Specifically, while prosocial orientation and guilt were found to be positively associated, when guilt was assessed with scenario measures; such an association was not evident when guilt was assessed with checklist measures. Thus, Tignor and Colvin (2016) argued whether the guilt assessed by checklist and the guilt assessed by scenario-based measures are the same construct or not.

In line with a possible multidimensionality of the guilt as a construct, several authors suggested different categorizations and aspects across which guilt feelings might differ. Zahn-Waxler and Kochanska (1990) defines adaptive and maladaptive guilt. In their conceptualization, adaptive guilt refers to the feeling that motivates reparative behaviors, while maladaptive guilt refers to the inordinate feeling that involves self-criticism and assuming responsibility for the things beyond one's control. In addition to the nature of the feeling, the difference between guilt as a reaction and guilt as an attribute was also suggested by several authors. For instance, the Guilt Inventory, developed by Kugler and Jones has three dimensions: moral standards, trait-guilt, and state-guilt (1992). Trait-guilt and moral standards dimensions correspond to whether someone generally feels guilty (without reference to any specific events) and the extent to which someone is subscribed to the standards of morality, respectively. State-guilt dimension, on the other hand refers to current feeling in respect to a specific situation. Very similarly, Quiles and Bybee (1997) conceptualize guilt as a two-dimensional construct: predispositional guilt and chronic guilt, first of which corresponds to the propensity to experience guilt as a reaction to situations that evoke guilt, and

the latter of which corresponds to guiltiness felt on an ongoing basis in the absence of any specific situation accompanied by regret and remorse. Not only for guilt, but also for shame, Wolf et al. (2010), makes a similar distinction between proneness to shame or guilt and being permanently guilt-ridden or shame-ridden.

In addition to the emphasis on the state-trait distinction, Bybee, Zigler, Berliner, and Merisca (1996) found that not guilt proneness per se but coping with guilt in a way that perpetuates and exacerbates it was related to the eating disorders. As an implication of their research findings, they advocate the importance of investigating different types of guilt.

Overall, the findings reported above all point to the observation that the adaptiveness of the guilt feelings are dependent upon the context in which it was experienced. From a theoretical stance, controversial findings on guilt verify the functionalist perspective that argues against the view that an emotion can be inherently adaptive or maladaptive. Instead, this perspective postulates that circumstances determine whether an emotion is functional or dysfunctional (Barrett, 1995; Campos, Mumme, Kermoian, Campos, 1994).

Overall, shame and guilt are considered as moral emotions in the sense that they facilitate morally acceptable behavior and impede transgression, by serving as punishment of unacceptable behavior. In this regard, shame and guilt are presumed to have adaptive functions; yet, empirical findings fail to fully support this presumption. While there is ample evidence for the adaptive functions of guilt, there is lack of evidence for the adaptive functions of shame. On the other hand, there is considerable evidence showing that guilt has also a maladaptive side to itself. Thus, the theoretical and empirical contributions on guilt and shame as moral emotions conclude in the necessity to examine them within the context in which they are aroused.

1.4. PSYCHOANALYTIC CONCEPTUALIZATIONS OF SHAME AND GUILT

The other field of psychology that put guilt and shame under spotlight, thus contributed to their conceptualization, is psychoanalytic theory. In the formative years of psychoanalysis, classical perspective portrayed guilt as having a crucial role for the configuration of the dynamic unconscious, and thus, personality and psychopathology. On the other hand, the role and importance of shame remained unappreciated for decades, until the contributions of self psychology that assigned a primary importance to it in the formation and disorders of the self. Thus, guilt and shame, respectively gained prominent emphasis over many other emotions, throughout psychoanalytic history.

1.4.1. Freudian Accounts on Guilt and Shame

Freud conceptualizes guilt, development of which is prerequisite for superego, as an outcome of Oedipus Complex (1924/1961c, 1930/1961a, 1923/1961d). According to the formulation put forward by Freud, the boy desires to have his mother as a partner and worries that his father will punish his desires. This castration anxiety provides the motive to the child for restraining from his oedipal desires and internalization of parental authority, the latter of which also constitutes the nucleus of the structure of superego (1924/1961c). According to this conceptualization guilt serves as a punishment to unacceptable impulses, which breaches internalized norms; thus, enabling human behavior to be in line with moral standards (Carni et al.,2013). Freud's formulation on superego formation in girls (1925/1961), on the other hand, suggests that being already castrated causes lack of castration fear in girls, which is the main factor in relinquishing oedipal desires in boys. This lack of fear results in slow and incomplete abandonment of oedipal desires in girls, which leads to rather weakly organized superego in females.

Freud also suggested that guilt does not only punishes unacceptable behavior but also motivates those who violate the standards to desire to be punished, and he deemed excessive amount of guilt as underlying all neurosis (1924/1961c). With its relation to masochistic tendencies, self-punishment aspect of guilt is widely embraced in psychoanalytic literature (Panken, 1983). Freud associated guilt with the fear of losing the love of first the parents, and, later of the people in one's social group (1914/1957), which was argued as an implication that Freud confounded shame with guilt (Lansky & Morrison, 1997; Tangney & Dearing, 2002).

In Freud's early formulations, shame was conceptualized as a painful affect, signaling the need for repression and he discussed shame with its association to morality as a factor underlying the banishment of ideas from awareness that threatens approval by others. Lansky and Morrison (1997) postulates that the pain associated with shame in Freud's early formulations not only pertains to the awareness of rejection by others, but also to the self's being conscious of itself as having aspects that are in conflict with the standards that determines acceptability. In his later writings, Freud viewed shame not only a motive for defense but also as a method of defense in the form of reaction formation (Freud, 1905/1953b; Lansky, 2005). From this perspective, disgust, shame and morality are opposing forces against libidinal exhibitionistic impulses, thus enabling us to behave in a civilized manner.

1.4.2. Developmental Ego Psychology and Object Relational Perspectives

Erik Erikson offers a developmental psychoanalytic perspective on ego development and identity formation by identifying eight stages characterized by dialectical tensions. Shame and guilt characterize the tensions of the second and the third stages of Erikson. In the second stage that coincide with the anal phase of development, the main conflict is between autonomy and shame. Shame emanates from the failure of achieving the task of this developmental stage that is to attain autonomy (Erikson, 1950). Guilt feelings, on the other hand, arise from acts of

initiative to achieve purpose in initiative versus guilt stage that may include aggressive attempts and thus fall afoul with the environment. In Erikson's conceptualization, shame is considered to be a more primitive and developmentally earlier emotion than guilt (Akhtar, 2015; Lewis, 1971).

Representing the object relational approach, one of Melanie Klein's (1945) most important contributions was to offer a novel conceptualization of guilt. Klein did not locate the emergence of the capacity for guilt at the end of the Oedipus Complex, instead she suggested that the course of Oedipus Complex is affected by guilt feelings from the very beginning. According to her formulation, when the child's needs are frustrated, it stimulates aggressive impulses and sadistic attacks toward frustrating objects in phantasy as the result of which anxiety of retaliation, and feelings of guilt arise. Feelings of guilt attain a prominent place in Klein's thinking on libidinal development in that it drives the child to repair the harm caused by his sadistic attacks through libidinal means, and it also ensures repression of libidinal desires when aggressive impulses prevail (Klein, 1945).

A model for the first emergence of shame from an object relational perspective is proposed by Schore (1991), in which he links the onset of shame to Mahler's practicing subphase of separation and individuation process. In Mahler's theory, development starts with the symbiotic union of the infant and the caregiver and moves toward the separation and individuation of the infant (Mitchell & Blank, 1995). During this process that includes recurring moments of separating and reuniting, the infant comes to the painful realization of its separateness from and dependency on the other, the caregiver. Schore (1991) zoomed in to this process and proposed that the first form of shame appears when this fragile self in an affective high arousal state is not met with a corresponding state in the caregiver at the time of reunion. In other words, the prototype for the experience of shame is the experience of affective misattunement.

Another conceptualization of shame was offered by Mollon (2005), who discussed the shame feelings as part of the understanding of the concept of false self, proposed by Winnicott (1965). Winnicott (1965) claimed that when the authentic experience of an infant is not contained with optimal responsiveness, the

infant gives up the actual self and develops a false self through a defensive compliance with the environment. In this regard, a false self serves a defensive function of hiding, and thus of protecting the true self, by complying the demands of the environment (Winnicott, 1965). Mollon (2005) argues that the actual self, which are perceived as unacceptable, and consequently experienced as shameful, is replaced by a false self. Thus, again, the feeling of shame is associated with the affective response of the environment.

In sum, contributions of developmental ego psychology and object relations approaches to the understanding of guilt and shame, converge on the first the portrayal of guilt as appearing earlier in development, preceding the Oedipus complex, and second the description of shame as a consequence of poor affect attunement to an emerging self.

1.4.3. Self Psychology

Kohut, who is the founder of the Self Psychology, made important contributions in understanding shame (1971, 1977). He first conceptualized shame as emanating from the frustration of the grandiose-exhibitionistic demands of the self (Kohut, 1996). In Kohut's theory, the infant needs the parents to serve functions pertaining to the development and preservation of self-continuity, self-coherence, self-love and self worth. Kohut uses the terms *selfobject* to refer to the way of relating with the other not as a separate object, but as an extension of self. According to Kohut, based on his formulations on transference, the earliest forms of these needs require the other to ensure greatness (mirroring) and offer merger with the idealized other (idealizing); and when they are not met, the individual seeks these functions in adult relationships (see Kohut, 1978). Within this framework, Kohut theorized that the experience of shame is caused by the combination of the power of the archaic exhibitionistic need that expects the confirmation of greatness, and the undisputable verdict that this need will not be fulfilled (Kohut, 1978). He further postulated that these deep feelings of shame lead to withdrawal and/or alternating anger outbursts. Guilt from Kohut's

perspective, on the other hand, is mentioned within the context of the need for merger with the idealized other. Kohut claimed that the absence of this experience may cause an unfounded and excessive self-blame that he equates with “guilt-depression”.

Morrison (2014) also commented on the association of shame with narcissism by stating that shame is a defining feature of narcissistic condition/phenomena just like guilt is of neuroses. According to Morrison (2014), Kohut’s conceptualization of shame is limited in that he associated shame only with disavowed grandiosity and not with the failure of parental selfobject in responding to idealizing needs of the self. Furthermore, Morrison also views shame as emanating from failing to meet the goals, which are aspired by the ideal self to be attained. The absence of adequate response to the need of self to be admired implies that the self lacks the control over its environment; thus, narcissistic rage serves the function of abolishing shame by reversing the passive position of the self into an active position. Similarly, Wurmser (2015) also considered shame and humiliation as possessing a prominent place in understanding of disturbances in the sense of cohesion and integrity, of self-esteem, that is narcissistic phenomena in the broadest sense as he put it.

1.4.4. Differentiating Shame and Guilt from Psychoanalytic Perspective

Based on the general picture outlined above, it is observable that guilt has been discussed more in the context of classical neurotic conflict due to Oedipal struggles, whereas shame has been reported more in relation to the disturbances of self, especially due to the absence of an affective response from significant others in early years. Yet, this distinction was rarely formally acknowledged.

The conceptual failure in distinguishing shame and guilt has been maintained by some followers of Freud (Hartman & Loewenstein, 1962), while some others attempted to distinguish them. One such attempt was made by Piers and Singer (1953/1971) as they emphasized the importance of understanding the coexistence of these emotions, and their interchange in a cyclical trend (Piers &

Singer, 1953/1971). Piers and Singer (1953/1971) suggested that shame is elicited when there is a conflict between the ego and the ego ideal. Failing to attain the ascribed goals that constitute the ego ideal, which damages the idealized image of self leads to shame and accompanies decrease in self-esteem (Akhtar, 2015; Morrison, 1983). Piers and Singer (1953/1971) viewed guilt as emanating from violating the dictates of the superego and associated guilt to the threat of castration, while they associated shame with the threat of being rejected and abandoned. Very recently, Wurmser (2015) also discusses the circularity of shame and guilt in the context of negative therapeutic reaction, defined as worsening of patient's condition subsequent to improvement. As an example, he refers to a case in which any attempt towards independence induces feelings of guilt, while dependency is accompanied by shame, which eventually leads to rage and to attempts toward independence; and thus, the circle repeats itself.

Some authors emphasized that shame in comparison to guilt is more related to identity, and has a personal quality (Lewis, 1971; Morrison, 2014; Thrane, 1979). Wurmser (1981) distinguishes shame and guilt on the ground that compared to self-orientedness of shame, object-relatedness becomes prominent in guilt. Wurmser (1981) also pointed out that guilt is related to inflicting pain on others or harming them, and thus, implicating a sense of powerfulness; while shame is linked to a sense of powerlessness. Therefore, in terms of defensive purposes owning feelings of guilt instead of shame might be favorable; since admitting the first implies power, though misused, and admitting the latter implies weakness and passivity (Lansky, 2005).

It is important to note that aforementioned literature is based largely on theoretical work and case studies, and lacks empirical work testing the assumptions of psychoanalytic conceptualizations of shame and guilt.

1.5. MEASUREMENT OF GUILT AND SHAME PRONENESS

Since there has been no consensus in the literature on conceptualization of shame and guilt, the issue of measuring guilt, shame, and proneness to experience

these emotions is also problematic. Depending on the theoretical perspective that underlies the operationalization process, the measurement tools of these constructs differ; leading to the contradictory findings related to the same construct.

Currently the number of measurement tools that have been developed in order to assess guilt proneness, shame proneness or both exceeds twenty (Tignor & Colvin, 2016). Those measures that have been designed to measure only one of the two constructs without regard to the other are especially earlier ones (Buss & Durke, 1957; Cook, 1989; Kugler & Jones, 1992). According to Tangney (1996), many of these earlier measures, the ones through which only guilt proneness is assessed in particular, fall into the error of not differentiating shame and guilt, and thus limiting the utility of the measurement tool in exploring the differential effects of shame and guilt. After the importance of differentiating these two emotions has gained acceptance, measures that assess both guilt proneness and shame proneness at the same time has increased. Measures that assess guilt and shame proneness simultaneously can be grouped under two categories: scenario-based and checklist measures (Tangney, 1996).

1.5.1. Checklist Measures

In a checklist format, respondents are presented with some guilt and shame related adjectives and required to rate to what extent those adjectives or affective experiences represent themselves. To exemplify, one of the widely used questionnaire in checklist format is Personal Feelings Questionnaire (PFQ) developed by Harder and Lewis (1987). PFQ asks respondents to rate each affective experience expressed lexically such as “remorse” for guilt proneness and “humiliation” for shame proneness in terms of the extent to which they experience them.

Construct validity of guilt proneness assessed by checklist measures has been questioned on the ground that responding to a checklist measure mimics the self-evaluative process that leads to shame, described by Lewis (1971), that is making global attributions about self instead of evaluating a specific act (Tangney

& Dearing, 2002). Therefore, especially when assessing guilt proneness, selecting a questionnaire designed with a checklist format might be problematic (Tangney, 1996). Furthermore, the validity of these questionnaires relies on the respondents' ability to accurately distinguish descriptors presented to them, that are related to the affective experience of shame and guilt. However, most people in fact struggle with differentiating shame and guilt (Tangney & Dearing, 2002), and when experiencing two emotions simultaneously they tend to name their merged affective experience as "guilt" (Lewis, 1971).

1.5.2. Scenario Measures

In a scenario-based format, respondents are presented with hypothetical situations that they are likely to encounter in their daily life and asked to rate the likelihood of responding to those situations on cognitive, affective and behavioral levels. The Test of Self Conscious Affect (TOSCA-3, Tangney, Dearing, Wagner, & Gramzow, 2000) is the most widely used assessment tool with scenario-based format for assessing proneness to shame and guilt. It consists of 16 scenarios and 4 possible reactions for each scenario that might be given in response to those situations. To exemplify, for a scenario in which a coworker is blamed for the mistake the person made, likelihood of "keeping quiet and avoiding the coworker", and "feeling unhappy and eager to correct the situation" indicated shame proneness and guilt proneness respectively.

Construct validity of guilt and shame proneness measures with scenario-based format has also been questioned in terms of their limitations and drawbacks. One argument includes the question of whether participants' responses indicate their actual tendency to experience guilt or their belief that they should experience guilt in the future if they encounter those scenarios presented to them (Tignor & Colvin, 2016). Similarly, Kugler and Jones (1992) argue that scenario-based measures pertain more to one's moral judgment, instead of the affective experience of guilt and proposed that in checklist measures, affective experience of guilt is tapped more accurately due to their decontextualized nature. Scenario-

based measures involve evaluation of the situations described in the questionnaire by respondents on the basis of their moral standards so that they can report the likelihood of responding to those situations emotionally or behaviorally in the stated way. In this respect, Tangney and Dearing acknowledge concerns, related to the role of moral standards as a confounding factor in measurement of guilt proneness with scenario-based measures (2002). However, they propose that it is a necessary compromise for the sake of differentiating shame and guilt proneness relying on self-versus behavior distinction. Comprising items of the situations that do not lead to divergence as to whether those situations are regarded as morally wrong or not by respondents has been reported as a way to minimize the role of moral standards as a confounding variable (Tangney, 1996). Another compromise relates to the selection of scenarios. Inclusion of scenarios in the questionnaires, approximating the events that might be encountered in real life, improves ecological validity of the instrument while limiting the representation of more unique situations that might evoke strong affective experience of shame or guilt (Tangney & Dearing, 2002).

Cohen et al. (2011) argued that not distinguishing between affective reactions and behavioral tendencies following transgressions is another limitation of TOSCA-3, widely used scenario-based measure. The merit of differentiating behavioral tendencies from affective reactions is validated by empirical research as well (Wolf et al., 2010). Furthermore, research findings indicate that feelings of shame does not exclusively elicit avoidance behaviors, it may also lead to adaptive and reparative behaviors as well (Gausel & Leach, 2011; Harris & Darby, 2009; Schmader & Lickel, 2006).

1.5.3. The Guilt and Shame Proneness Scale (GASP)

The Guilt and Shame Proneness Scale is a self-report measure that assesses one's proneness to experience shame and guilt. It was developed by Cohen et al. (2011) and consists of 16 items. Each item contains a transgression scenario together with a possible reaction that might be given in that situation and

respondents are expected to rate the likelihood of feeling, behaving or thinking in the stated way for each scenario on a 7 point scale, ranging from “very unlikely” to “very likely”. The scale has four subscales: negative behavior evaluations (NBEs) and guilt-repair behaviors for guilt proneness; negative self evaluations (NSEs) and shame-withdraw behaviors.

Cohen et al. (2011) indicated that compared to other measures that have been developed so far, GASP has certain advantages. First, it is the first measure that incorporates two theoretical approaches that distinguish shame and guilt: public versus private distinction and self-versus behavior distinction. In GASP, items that describe publically exposed transgressions aim at assessing shame proneness, while scenarios that include private transgressions aim at assessing guilt proneness. This choice is grounded in public private distinction. GASP also distinguishes shame and guilt proneness on the ground that whether negative evaluations are directed toward self-versus behavior. Second, GASP also recognized the importance of differentiating emotional responses from behavioral ones. By doing so it makes an important contribution to the field by showing that maladaptive side of shame does not come from negative evaluation of self, rather, avoidance behaviors are responsible for the maladaptive features of shame.

This discriminations between public vs. private and self vs. behavior, in addition to its potential contributions to further understand the adaptive and maladaptive functions of different dimensions of shame and guilt, point to an important need in the psychoanalytic understanding of these emotions. The Negative Behavior Evaluation (NBE) element of the GASP might capture a more classical-Oedipal conceptualization of guilt as the punishment expectation on the basis of a transgression, whereas Guilt-repair component might be associated with the Kleinian conceptualization in terms of the reparation of the destroyed object. Further, Negative Self Evaluation as an aspect of shame could be portrayed as the rather narcissistic issues that had been mentioned by both Mahler and Kohut. Shame-withdrawal might on the other hand be related to the protective hiding as would be suggested both by Winnicott and Kohut. These potential connections indicate that these latent factors as suggested by the authors of the scale, might

serve as a basis for further study of their correlates and shed light on the pre-oedipal and oedipal dynamics that are associated with different dimensions of shame and guilt, as defense-provoking and also reparative and protective.

1.6. PRESENT STUDY

The aim of the present study is to adapt GASP to Turkish and evaluate psychometric properties of its Turkish version. There is only one tool that is specifically developed for assessing shame and guilt at state level in Turkish (Şahin & Şahin, 1992). There are other measurement tools that were adapted to Turkish, namely The Trait Shame and Guilt Scale (Rohleder, Chen, Wolf, & Miller, 2008; adapted by Bugay & Demir, 2011), The Test of Self-Conscious Affect (Tangney et al., 2000; adapted by Motan, 2007), Offence-related Feelings of Shame and Guilt Scale (Wright & Gudjonsson, 2007; adapted by Sarıçam, Akın, & Çardak, 2012). However, none of those measurement tools assesses proneness to shame and guilt while differentiating the action tendencies and affective component of these two emotions.

Considering the advantages of GASP over existing tools that measure guilt and shame proneness as discussed in detail in preceding section, adapting GASP to Turkish would be an important contribution to the understanding of shame and guilt in Turkish culture. Having GASP subscales available for measurement is expected to clarify, the similarities and distinctions of guilt and shame both as moral emotions and dynamics of the psyche.

METHOD

2.1. PARTICIPANTS

The only inclusion criteria for participating in the study was being 18 years of age or older. Initially, 401 people consented to participate in the study and completed the survey. Data of 6 participants are excluded since their native

language was not Turkish. Data of another 12 participants were also excluded since their scores on the item (sixth item of Moral Foundations Scale's Turkish Form), serving as a check for whether their response was meaningful, was high (5 on a 6 point Likert scale ranging from 0 to 5), which indicated careless responding. All analysis was conducted with the data of remaining 383 participants. Females constituted 74.2 % of the sample (N=284), while only 25.8 % of the sample was male (N=99). Age of the participants ranged from 18 to 71 ($M = 35.92$, $SD = 12.27$). As to their marital status, 182 (47.5%) of the participants was married, while 170 (44.4%) of them reported being single. Only 2 participants reported their marital status as widow, whereas 19 participants reported they were divorced and 10 participants chose 'other' option.

The level of completed education was high school for 93 (24.3%), associate's degree for 34 (8.9%), bachelor's degree for 150 (39.2%), master's degree for 79 (20.6%), and doctoral degree for 19 (5.0%). Primary and secondary school was reported as the level of completed education by only 2 and 6 participants respectively. As to their employment status, 51.2% reported having a full-time job, while 10.2% reported having a part time job, while 15 (3.9%) stated that they are unemployed and 63 (16.4%) participants reported that they are students. 'Other' option was chosen by 39 (10.2%) and 31 (8.1%) participants reported that they do not prefer working. Monthly income was more than 5000 Turkish Liras for 30% of the participants, 4000-4999 Turkish Liras for 10.4%, 3000-3999 Turkish Liras for 14.9%, 2000-2999 Turkish Liras for 11%, and less than 2000 Turkish Liras for 15.9%. 17.8% did not want to specify their level of income.

As to their residence, 82% stated that they spent most of their lives in a big city, and 13.3% in small cities. Only 5 participants reported that they spent most of their lives in a town or village, and the remaining 13 participants reported to have lived in a foreign country. A great majority of the participants (366; 95.6%) resided in Turkey at the time of the study, whereas a European country was reported as the country of residence by 16 (4.2%), and America by only 1 (0.3%) participant.

Since the original scale construction study did not exclude any participant on the basis of demographic characteristics, this study also included all valid data from Turkish-speaking participants for further analyses.

2.2. INSTRUMENTS

In this study, in order to ensure informed and voluntary participation of the sample an informed consent form was presented; and to be able to outline the characteristics of the sample a demographic information form was used. As the primary focus of the study Guilt and Shame Proneness Scale (GASP) was administered. Further, in order to provide evidence on the validity of the GASP scale, Moral Foundations Questionnaire, Big Five Inventory, and Aggression Questionnaire were selected and administered on the basis of studies that showed how shame and guilt relate to aggression (Cohen et al., 2011), personality dimensions (Erden & Akbağ, 2015) and moral foundations (Rebega, 2017). Brief descriptions and psychometric properties of each instrument are presented below.

2.2.1. Informed Consent Form

The first form presented in the survey was the informed consent form, which asked the respondent's voluntary participation for the study (See Appendix A). In the form, the aim of the study was briefly explained as adapting a scale, measuring one's propensity to experience certain emotions, to Turkish. Participants were also informed about their right to stop participating in case of experiencing distress and to contact the researcher if they have any questions related to the study.

2.2.2. Demographic Information Form

Participants were asked to answer questions regarding their gender, age, marital status, level of income, employment status, education level, city and

country of residence and mother tongue. A question about the characteristics of the place where they spent most of their lives was also included in the form (See Appendix G).

2.2.3. Guilt and Shame Proneness Scale (GASP)

The Guilt and Shame Proneness Scale, developed by Cohen et al. (2011) is a 16-item scale, which measures one's proneness to experience shame and guilt. Each item contains a transgression scenario together with a possible reaction that might be given in that situation (e.g., "You give a bad presentation at work. Afterwards your boss tells your coworkers it was your fault that your company lost the contract. What is the likelihood that you would feel incompetent?"). Respondents are expected to rate the likelihood of feeling, behaving or thinking in the stated way for each scenario on a 7-point scale, ranging from "very unlikely" to "very likely". The scale consists of four subscales: Guilt-NBE (Negative Behavior Evaluations), Guilt-Repair, Shame-NSE (Negative Self Evaluations), Shame-Withdraw. A score for each subscale is calculated by taking the average of the four items related to that subscale. The scale was reported to be a reliable measure given that alpha coefficients of each subscale exceeded .60 (Cohen et al., 2011).

The original English version of the scale (See Appendix B) was translated to Turkish by the author. Following the initial inspection of the translation by the author and the advisor, back translations were performed by a second scholar, who was competent in both languages. After the revisions done on the basis of the comparison between the back translations and the original scale, the scale was sent to 3 experts who had MA degrees in different specializations of Psychology and had experience with both the theoretical and empirical work on guilt and shame. The experts were asked to comment on the clarity of items and congruity of the language to the culture. All revisions suggested by the experts were minor, and mostly about the cultural applicability of certain situations described in the

items. All suggested revisions were done. Thus, the Turkish version of the scale reached its final form (See Appendix C).

2.2.4. Moral Foundations Questionnaire

Moral Foundations Questionnaire, psychometric features of which were established by Graham et al. (2011), measures how much importance the respondents attribute to each of the five moral foundations when they make moral decisions, namely harm/care, fairness/reciprocity, ingroup/loyalty, authority/respect, purity/sanctity. The scale is composed of 30 items, rated on 6 point Likert-type scale, and divided into two parts (See Appendix D). In the first part, respondents are asked to indicate how much importance they attribute to a given foundation in their moral decision-making process (e.g., “Whether or not someone acted unfairly”). In the second section, they are asked to rate their level of agreement with the given foundation (e.g., “One of the worst things a person could do is hurt a defenseless animal”). For each moral foundation, respondents are given a composite score by averaging the scores of six items relevant to a given foundation from two parts of the questionnaire.

Yılmaz, Harma, Bahçekapılı and Cesur (2016) adapted the questionnaire to Turkish. In that study, original five-factor model was confirmed and satisfactory internal reliability scores were reported ($\alpha = .60$ for harm, $\alpha = .57$ for fairness, $\alpha = .66$ for ingroup, $\alpha = .78$ for authority, and $\alpha = .76$ for purity).

Internal consistency for each subscale in the present study was also checked using Cronbach’s alpha coefficients and found to be as .63 for harm, .46 for fairness, .63 for ingroup, .73 for authority, and .74 for purity. Cronbach alpha values of all subscales except fairness dimension was found to be acceptable. Since fairness subscale showed poor internal reliability for this sample, it was not included in the further analyses.

2.2.5. Big Five Inventory

The Big Five Inventory (BFI), developed by John, Donahue and Kentle (1991), is designed to assess five dimensions of personality: extraversion, agreeableness, conscientiousness, neuroticism and openness. Respondents are asked to rate how much they agree with each of 44 short items on 5-point Likert type scale, ranging from “strongly agree” to “strongly disagree”.

The study that adapted BFI to Turkish was carried out by Karaman, Dogan, & Çoban (2010). Turkish version of the BFI consists of 40 short items instead of 44 as in the original questionnaire (See Appendix F). For the Turkish version of the inventory, internal consistency of all subscales was found to be high ($\alpha = .77$ for extraversion subscale, $\alpha = .81$ for agreeableness, $\alpha = .84$ for conscientiousness, $\alpha = .75$ for neuroticism and $\alpha = .86$ for openness).

In the present study, extraversion, conscientiousness, neuroticism, openness subscales showed good internal reliability, while internal reliability coefficient for agreeableness subscale was acceptable (for extraversion $\alpha = .83$, for neuroticism $\alpha = .75$, for openness $\alpha = .75$, for conscientiousness $\alpha = .76$, for agreeableness $\alpha = .62$).

2.2.6. Buss-Warren Aggression Questionnaire

Buss-Warren Questionnaire, developed by Buss and Warren (2000), measures respondents' level of aggression. The questionnaire was built on Buss and Perry Aggression Questionnaire (Buss & Perry, 1992). The revision made by Buss and Warren (2000) includes alterations in the items to enhance their clarity and adding the indirect aggression subscale, which is not included in the previous version of the questionnaire. It consists of 34 items rated on a 5-point Likert type scale and its five subscales measure verbal aggression, physical aggression, anger, hostility and indirect aggression. The composite score one respondent can obtain ranges from 34 to 170. Higher scores indicate higher levels of aggression for each domain.

The questionnaire was adapted to Turkish by Can (2002). Her study revealed that Turkish version of Aggression Questionnaire (See Appendix E) have good internal reliability, as suggested by the Cronbach alpha value of .92 for the total scale.

Internal consistency scores of the scale in the present study was also found to be .90 for the total scale; and ranging from acceptable to high for each subscale ($\alpha = .85$ for physical aggression, $\alpha = .66$ for verbal aggression, $\alpha = .60$ for anger, $\alpha = .71$ for hostility, and $\alpha = .54$ for indirect aggression).

2.3. PROCEDURE

Upon receiving ethical approval for the study from Ethics Committee Board of Istanbul Bilgi University, data collection process was started. The data for the present study was collected online through Survey Monkey. The web link created for the survey was shared through various online platforms in order for the sample to be as large and representative as possible. Participants were first presented with the informed consent form, which includes a brief information about the purpose of the study and asks their voluntary participation for the study. After agreeing to participate, all participants were asked to fill out the Turkish version of the Guilt and Shame Proneness Scale. For the rest of the inventories (Moral Foundations Questionnaire, Big Five Inventory and Aggression Questionnaire) except the demographic form, which was administered last, the presentation order was randomized for each participant.

RESULTS

3.1. FACTOR STRUCTURE OF GASP

3.1.1. Confirmatory Analysis and Reliability of The Original Factor Structure

Cohen et al. (2011) developed items for each subscale separately and conducted separate EFAs in order to achieve internally consistent subscales. The authors reported that they were "...less concerned with the overall factor structure of the GASP and more concerned with developing four internally reliable subscales" (p. 18). Following Cohen et al.'s (2011) approach, initially in this study, the original model was tested in terms of model fit and internal consistency in order to identify whether the suggested model could adequately explain the variance in the Turkish version.

Using the whole sample, the original model had a poor fit (chi-square $p = .000$; TLI $\rho^2 = .37$; CFI = .49). Modification indices suggested linkages that cross over to other factors than the ones suggested by the original model. Similarly, reliability coefficients showed poor internal consistency for all almost subscales ($\alpha = .569$ for Guilt NBE, $\alpha = .438$ for Guilt Repair, $\alpha = .482$ for Shame NSE, and $\alpha = .145$ for Shame Withdrawal).

In order to identify the best model that explains the covariances of the items in the Turkish version; an exploratory analysis followed by a confirmatory analysis was conducted from scratch. Since initial item pool was not available in this study; instead of conducting separate EFAs for each subscale, a single exploratory analysis with Principal Axis Factoring was conducted, and the findings were interpreted with the perspective that the concern was to identify internally reliable subscales.

As performed by Cohen et al. (2011) in their initial study, approximately 50% of the Turkish sample was randomly selected and used for exploratory analyses ($N = 189$), whereas the remaining ($N = 194$) was used for the

confirmatory analysis. Statistical Package for the Social Sciences Version 24.0 (SPSS) was used for exploratory analyses; and the AMOS module was used for confirmatory analyses.

3.1.2. Exploratory Analyses with the Turkish Sample

First, the central tendency, dispersion and distributions of all GASP items were inspected (See Table 1). Items 1, 3 and 9 had high means, and slightly problematic distributions according to the $-/+ 2$ rule (George & Mallery, 2010). Since the skewness and kurtosis scores were not extreme, the decisions about these items were postponed to be made after factor analysis.

Table 1
The Descriptive Statistics of GASP Items

	Min	Max	M	SD	Skewness	Kurtosis
GASP1	1	7	6.25	1.550	-2.267	4.266
GASP2	1	7	5.27	1.776	-0.737	-0.335
GASP3	1	7	6.24	1.438	-2.116	3.912
GASP4	1	7	2.53	1.718	0.768	-0.476
GASP5	1	7	5.40	1.759	-0.957	0.164
GASP6	1	7	5.90	1.565	-1.524	1.788
GASP7	1	7	3.11	1.584	0.222	-0.579
GASP8	1	7	2.55	1.900	0.947	-0.341
GASP9	1	7	6.22	1.595	-2.277	4.293
GASP10	1	7	5.77	1.771	-1.529	1.468
GASP11	1	7	6.03	1.315	-1.327	1.363
GASP12	1	7	3.68	1.993	0.247	-0.930
GASP13	1	7	5.22	2.040	-0.925	-0.390
GASP14	1	7	5.50	1.945	-1.092	0.009
GASP15	1	7	5.78	1.429	-1.114	0.771
GASP16	1	7	5.49	1.838	-1.101	0.264

In the second step, an Exploratory Factor Analysis (EFA) was conducted using all GASP items. The weighted least squares extraction method and Direct Oblimin rotation method as suggested by the original study for separate EFA's resulted in "one or more communality estimates greater than 1," thus, the solution was deemed questionable.

In the third step, EFA was repeated with the more conventional method of extraction as Principal Axis Factoring, and again with Direct Oblimin as the rotation method. The sampling adequacy (KMO = .690) and factorability (Bartlett's Test of Sphericity; $\chi^2(120) = 454.328, p = .000$) were confirmed. A 4-factor solution explained approximately 46% of the variance. The initial factor structure with loadings is presented in Table 2.

Table 2
Pattern Matrix for Exploratory Factor Analysis

	Factor 1	Factor 2	Factor 3	Factor 4
GASP3	0.562	0.135	-0.11	0.179
GASP9	0.555	0.228		-0.267
GASP1	0.538			-0.144
GASP16	0.521		0.319	
GASP14	0.353		0.233	
GASP12	0.343		0.132	0.268
GASP6		0.645		
GASP13		0.484		
GASP7		0.317	-0.115	0.228
GASP10	0.286	0.305	0.304	-0.209
GASP11			0.607	
GASP15			0.54	
GASP5			0.402	
GASP2	0.112	0.102	0.287	
GASP8				0.392
GASP4				0.23

Extraction Method: Principal Axis Factoring.
Rotation Method: Oblimin with Kaiser Normalization.

Since Cohen et al.'s approach was to end up in internally consistent subscales (2011); the findings were inspected in coordination with the match between the original subscales and the factors structure of this study.

It was observed that Items 2, 5, 11 and 15 were grouped together as Factor 3; precisely representing the Guilt Repair subscale of the original scale. Items 6, 10 and 13 were grouped together as Factor 2 in this study, as in the original subscale of Shame NSE. Items 4 and 8, which were both items of the original subscale Shame Withdrawal constituted Factor 4 in this analysis. Last, Items 1, 9, 14, and 16 that represented the Guilt NBE subscale were also grouped together under Factor 1.

For only 3 of the 16 items that are Item 3, Item 7 and Item 12, the highest factor loadings suggested inclusion in a different factor than the original subscale composition. For these items second highest loadings were checked for possible inclusion in another factor that might match the original subscale. If that was not feasible, the item was eliminated. Following this process, Item 3 that was originally included in Shame NSE subscale was grouped together with Guilt NBE items that constituted Factor 1 in this analysis and had similar loadings for all the other factors. It could not have been further tested as a part of the theoretically suggested configuration, thus it was eliminated. On the other hand, Items 7 and 12, which were both originally included in the Shame Withdraw subscale, had the second highest loading for Factor 4 with Items 4 and 8, which are the other two items of Shame Withdraw subscale. Thus, these two items were cautiously included in order to defer the decision to retain or eliminate for after the confirmatory analysis. A summary of the initial and revised factor structures are presented in Table 3.

Table 3
Changes in the Initial Model of Factor Structure

	Factor in the initial structure	Factor in the revised structure
GASP9	1	1
GASP1	1	1
GASP16	1	1
GASP14	1	1
GASP6	2	2
GASP13	2	2
GASP10	2	2
GASP11	3	3
GASP15	3	3
GASP5	3	3
GASP2	3	3
GASP8	4	4
GASP4	4	4
GASP7*	2	4
GASP12*	1	4
GASP3**	1	-

*Included in Factor 4, that is the second highest loading for the item

**Eliminated since, it could not have been integrated into a theoretically meaningful and statistically appropriate factor.

3.1.3. Confirmatory Analyses with the Turkish Sample

The factor structure suggested by the exploratory analyses described above was tested on the remaining half of the sample. Initially, the model shown in Figure 1 was formulated and tested. The Figure shows that the model includes the paths from each GASP item to the designated latent factor, and since the factors are extracted with an oblique rotation that allows them to be correlated with each other, covariances between the latent factors.

Figure 1. Confirmatory Factor Analysis of the Initial Model

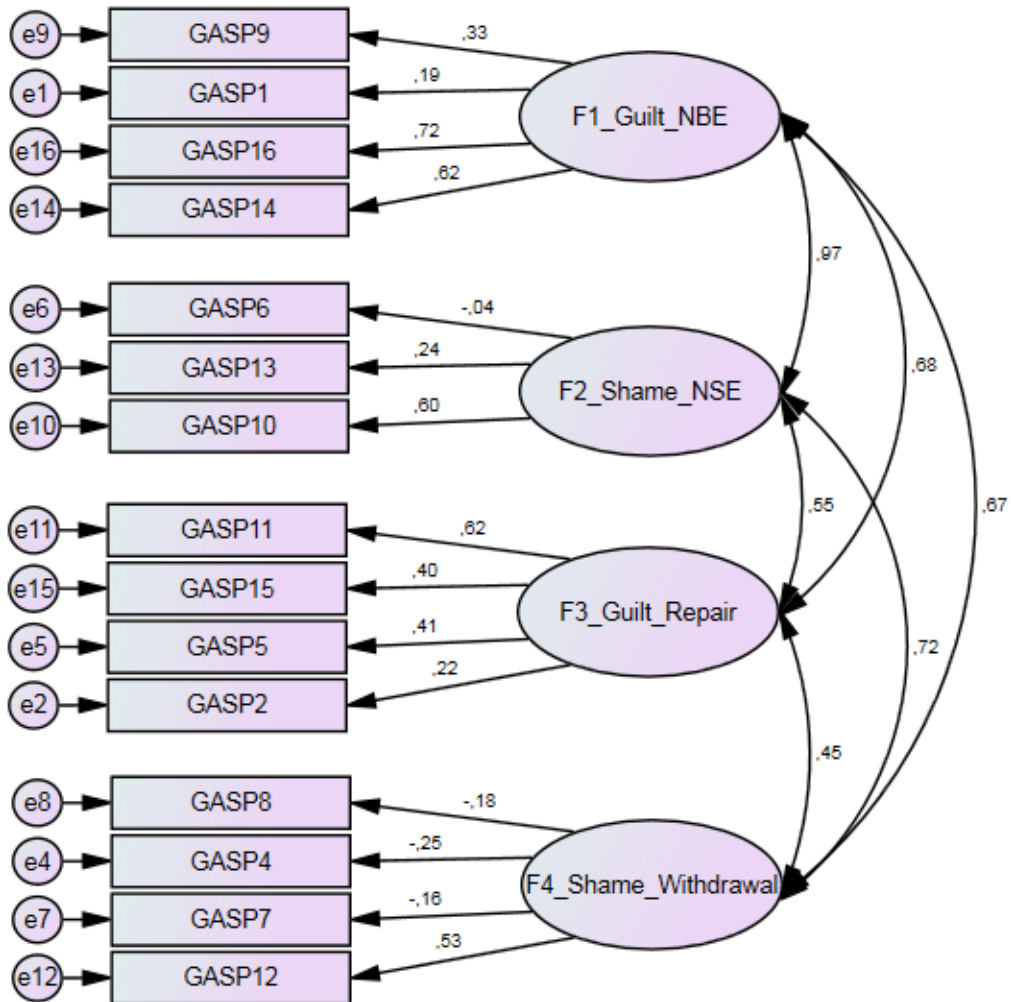

This initial model that was directly adopted from the exploratory analyses did not demonstrate an acceptable fit. Using the information from exploratory analyses and the indices of the confirmatory analysis, several modifications were made. Since Item 1, which was observed to have a high mean and skewed distribution in the initial inspection, a low loading (.19) that might have contributed to the poor fit of the model. Thus, it was eliminated. Similarly, Item 6 also had an extremely low loading in the model, thus it was eliminated.

Further, in the initial model it was observed that the Factor 4 had confusing loadings to all items, 3 of them being low and negative. Since, Items 7 and 12 were added to this factor as the second highest loading during EFA, they were selected as the items to be removed before further testing.

Following these modifications, the model fit considerably improved. Still, the item with the lowest loading for Factor 3 (Item 2) was further removed and the resulting model (See Figure 2) demonstrated an acceptable fit, as suggested by the non-significant Chi-square ($p = .083$), RMSEA = .044; CFI = .94; TLI rho-2 = .905.

Figure 2. Confirmatory Factor Analysis of the Modified Model

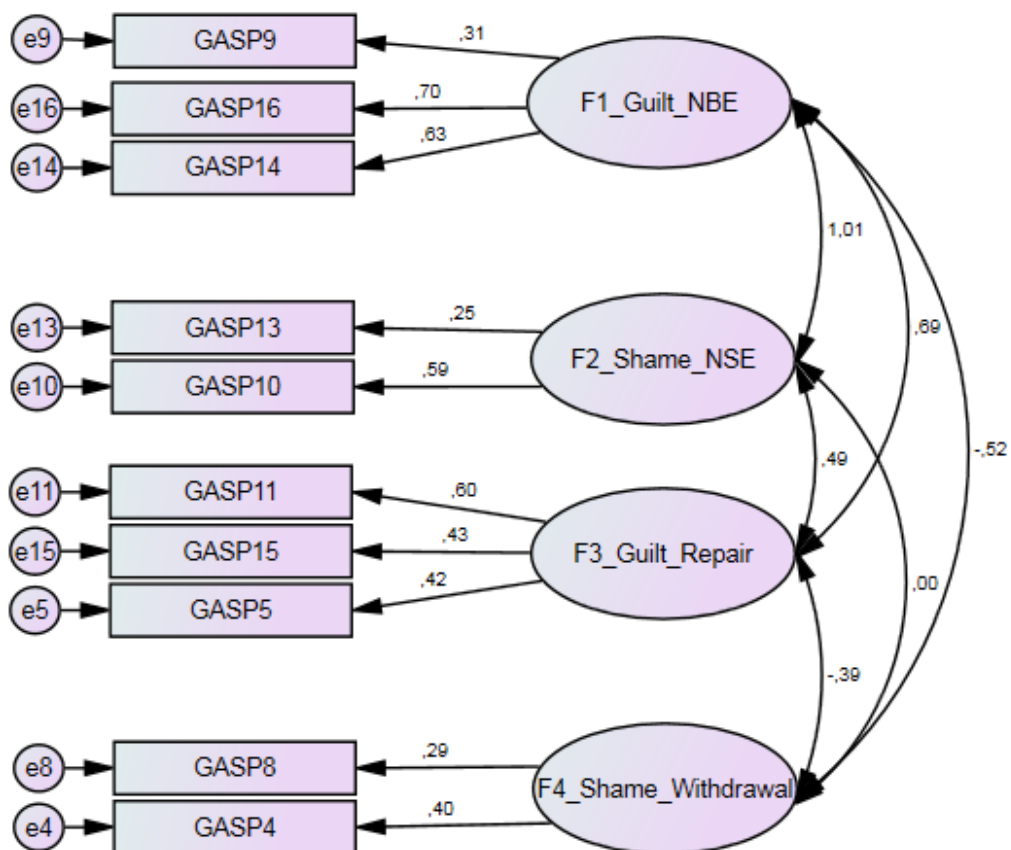

Table 4 presents a summary of the EFA and CFA findings that yielded final factor composition of Turkish version of the scale. The model suggests that Guilt NBE and Guilt Repair can be confirmed for the Turkish data, each missing one item (Item 1, and Item 2 respectively). Shame NSE and Shame Withdraw remained with 2 items each. For shame NSE subscale, item 10 and 13 were confirmed. Item 3 was dropped from the factor, since its highest factor loading suggested inclusion in guilt NBE factor, instead of shame NSE as in the original factor structure, and it was observed to have similar loadings to all the other factors, which made its integration to theoretically meaningful factor infeasible. Item 6 was excluded from the factor representing shame NSE in the Turkish version due to its low loading. Shame withdraw subscale remained item 4 and 8. Items 7 and 12 highest loadings of which suggested their inclusion to shame NSE and guilt NBE respectively were included in the shame withdraw factor since their second highest loadings suggested their integration to shame withdraw factor. However confirmatory factor analysis revealed that shame withdraw factor had low and negative loadings to items 4, 7, and 8. Since item 7 and 12 were added to the factor during EFA, they were selected to be removed from the factor.

Table 4. Summary of EFA and CFA Findings

Items of GASP	Factor in the Original Study	EFA of Turkish version	CFA of Turkish version
1. After realizing you have received too much change at a store, you decide to keep it because the salesclerk doesn't notice. What is the likelihood that you would feel uncomfortable about keeping the money?	Guilt NBE	Guilt NBE	Not confirmed**
9. You secretly commit a felony. What is the likelihood that you would feel remorse about breaking the law?	Guilt NBE	Guilt NBE	Confirmed

Table 4 (continued). Summary of EFA and CFA Findings

<p>14. At a coworker’s housewarming party, you spill red wine on their new cream-colored carpet. You cover the stain with a chair so that nobody notices your mess. What is the likelihood that you would feel that the way you acted was pathetic?</p>	<p>Guilt NBE</p>	<p>Guilt NBE</p>	<p>Confirmed</p>
<p>16. You lie to people but they never find out about it. What is the likelihood that you would feel terrible about the lies you told?</p>	<p>Guilt NBE</p>	<p>Guilt NBE</p>	<p>Confirmed</p>
<p>2. You are privately informed that you are the only one in your group that did not make the honor society because you skipped too many days of school. What is the likelihood that this would lead you to become more responsible about attending school?</p>	<p>Guilt Repair</p>	<p>Guilt Repair</p>	<p>Not confirmed**</p>
<p>5. You reveal a friend’s secret, though your friend never finds out. What is the likelihood that your failure to keep the secret would lead you to exert extra effort to keep secrets in the future?</p>	<p>Guilt Repair</p>	<p>Guilt Repair</p>	<p>Confirmed</p>
<p>11. You strongly defend a point of view in a discussion, and though nobody was aware of it, you realize that you were wrong. What is the likelihood that this would make you think more carefully before you speak?</p>	<p>Guilt Repair</p>	<p>Guilt Repair</p>	<p>Confirmed</p>
<p>15. While discussing a heated subject with friends, you suddenly realize you are shouting though nobody seems to notice. What is the likelihood that you would try to act more considerately toward your friends?</p>	<p>Guilt Repair</p>	<p>Guilt Repair</p>	<p>Confirmed</p>

Table 4 (continued). Summary of EFA and CFA Findings

<p>3. You rip an article out of a journal in the library and take it with you. Your teacher discovers what you did and tells the librarian and your entire class. What is the likelihood that this would make you would feel like a bad person?</p>	<p>Shame NSE</p>	<p>Guilt NBE*</p>	<p>Not confirmed</p>
<p>6. You give a bad presentation at work. Afterwards your boss tells your coworkers it was your fault that your company lost the contract. What is the likelihood that you would feel incompetent?</p>	<p>Shame NSE</p>	<p>Shame NSE</p>	<p>Not confirmed**</p>
<p>10. You successfully exaggerate your damages in a lawsuit. Months later, your lies are discovered and you are charged with perjury. What is the likelihood that you would think you are a despicable human being?</p>	<p>Shame NSE</p>	<p>Shame NSE</p>	<p>Confirmed</p>
<p>13. You make a mistake at work and find out a coworker is blamed for the error. Later, your coworker confronts you about your mistake. What is the likelihood that you would feel like a coward?</p>	<p>Shame NSE</p>	<p>Shame NSE</p>	<p>Confirmed</p>
<p>4. After making a big mistake on an important project at work in which people were depending on you, your boss criticizes you in front of your coworkers. What is the likelihood that you would feign sickness and leave work?</p>	<p>Shame Withdraw</p>	<p>Shame Withdraw</p>	<p>Confirmed</p>
<p>7. A friend tells you that you boast a great deal. What is the likelihood that you would stop spending time with that friend?</p>	<p>Shame Withdraw</p>	<p>Shame NSE***</p>	<p>Not confirmed</p>

Table 4 (continued). Summary of EFA and CFA Findings

8. Your home is very messy and unexpected guests knock on your door and invite themselves in. What is the likelihood that you would avoid the guests until they leave?	Shame Withdraw	Shame Withdraw	Confirmed
12. You take office supplies home for personal use and are caught by your boss. What is the likelihood that this would lead you to quit your job?	Shame Withdraw	Guilt NBE***	Not confirmed

* Eliminated since, it could not have been integrated into a theoretically meaningful and statistically appropriate factor

** Eliminated due to low factor loading

*** Included in shame withdraw factor as their second highest factor loading suggested

3.2. RELIABILITY OF GASP SUBSCALES

In order to test the the internal consistency of each factor, as identified by the confirmatory factor analyses, Cronbach’s alpha values were computed for the items that constitute that factor for the whole sample of 383 participants.

The Cronbach’s alpha was found as .54 for Guilt NBE and as .47 for Guilt Repair. Considering that guilt subscales in the Turkish version of the GASP consist of only 3 items each, and the internal reliability scores are slightly below the score of .60, which was determined as a benchmark for good internal reliability in the original study (Cohen et al., 2011), guilt subscales were further tested for construct validity.

Only 2 items of each shame subscale were confirmed for the Turkish version of the study. The internal consistencies were found to be poor for both, as would be expected from their problematic fit and low number of items ($\alpha = .32$ for Shame NSE, and as .24 for Shame Withdraw). The scores for these subscales were calculated and presented in further validity analyses for exploratory

purposes, but since they do not provide reliable measures, interpretations on the basis of these analyses are withheld.

3.3. CONSTRUCT VALIDITY OF THE GASP SUBSCALES

In order to test the construct validity of GASP subscales, first subscale scores were calculated by taking the mean of the items that were confirmed to constitute each factor. Further, scores derived from Moral Foundations Questionnaire, Big Five Inventory, and Aggression Questionnaire were also calculated. Descriptive statistics of all scores are presented in Table 4.

Table 5
Descriptive Statistics for Study Variables

	N	Minimum	Maximum	Mean	Std. Deviation
BFI					
Openness	383	19	50	35.54	5.602
Neuroticism	383	9	40	24.40	5.768
Conscientiousness	383	16	40	29.23	4.924
Agreeableness	383	11	35	27.97	3.573
Extraversion	383	7	35	22.60	5.245
AQ					
Indirect Aggression	383	6	24	12.24	3.389
Hostility	383	7	35	16.67	4.893
Anger	383	10	36	19.25	4.684
Verbal Aggression	383	5	25	13.58	3.400
Physical Aggression	383	8	40	13.80	5.619
MFQ					
Harm	383	6	30	23.92	4.107
Ingroup	383	2	30	18.79	5.068
Authority	383	0	30	15.99	5.677
Purity	383	2	30	17.65	6.212
GASP					
Guilt-NBE	383	6	21	17.20	3.878
Guilt-Repair	383	3	21	17.24	3.140
Shame-NSE	383	2	14	10.97	2.916
Shame-Withdraw	383	2	14	5.07	2.701

In the following sections, correlations among GASP subscales and correlations between GASP subscales and other relevant measures listed above will be presented as indicators of validity.

3.3.1. Correlations among GASP Subscales

As can be seen in Table 5, significant correlations were found between all subscales, except Shame-withdraw. Guilt-NBE and guilt-repair subscales correlated positively ($r = .48, p < .01$), indicating that for those who are more likely to make negative behavior evaluations, taking reparative action tendencies following transgressions is also a likely response. Guilt-NBE was also found to be positively correlated with shame-NSE ($r = .43, p < .01$). Although small in magnitude, guilt-repair subscale was positively associated with shame-NSE ($r = .22, p < .05$). However, no statistically significant correlation was found between the two shame subscales. The only association of shame-withdraw with other subscales of GASP was with guilt-NBE, and the direction of the correlation was negative ($r = .11, p < .05$).

Table 6
Subscale Correlations of GASP

	Shame-Withdraw	Guilt-Repair	Guilt-NBE	Shame-NSE
Shame-Withdraw	1	-.07	-.11*	.03
Guilt-Repair	-.07	1	.36**	.22**
Guilt-NBE	-.11*	.36**	1	.43**
Shame-NSE	.03	.22**	.43**	1

* $p < 0.05$, ** $p < 0.01$

3.3.2. Correlations between GASP Subscales and Other Measures

Pearson correlation coefficients of GASP subscale scores and all subscales of Moral Foundations Questionnaire –excluding fairness–, Big Five Inventory, and

Aggression Questionnaire were calculated for the verification of validity. Results are presented in Table 6. It should again be noted that each shame subscale in Turkish version of GASP consists of only two items instead of four as in the original scale and demonstrated low internal consistency. Hence, the results of correlational analysis of shame subscales with other study variables are presented in order to provide relevant data for future studies with GASP, and must be evaluated cautiously.

All guilt related subscales were found to be negatively associated to physical aggression, verbal aggression, anger, hostility, and indirect aggression. All of the correlations were significant. However, for shame subscales correlations showed a distinct pattern. While shame NSE negatively correlated with each subscale of Aggression Questionnaire, shame withdraw was found to be positively associated with hostility and indirect aggression subscales, although the correlations were small in magnitude.

In terms of personality characteristics, both guilt NBE and guilt repair subscales positively correlated with conscientiousness and agreeableness. Guilt repair positively correlated with openness to experience. Neuroticism was found to be positively correlated with shame withdraw, whereas it correlates negatively with guilt subscales. Extraversion correlated negatively with shame withdraw, and positively with guilt NBE subscale. Shame NSE only correlated with agreeableness subscale.

Both guilt NBE and guilt repair subscales correlated positively with harm, ingroup, and purity. Guilt NBE also correlated positively with moral foundation of authority. Shame NSE positively correlated with harm, and purity. There found no association between shame withdraw and any of the moral foundations measured by MFQ in the present study.

Table 7**Bivariate Correlations of GASP with Other Study Variables**

	Shame- Withdraw	Guilt- Repair	Guilt-NBE	Shame- NSE
<u>Aggression Questionnaire</u>				
Physical Aggression	.00	-.22**	-.34**	-.23**
Verbal Aggression	.05	-.27**	-.28**	-.22**
Anger	.06	-.30**	-.25**	-.15**
Hostility	.12*	-.25**	-.23**	-.11*
Indirect Aggression	.12*	-.23**	-.40**	-.18**
<u>Big Five Inventory</u>				
Extraversion	-.12*	.09	.12*	-.03
Agreeableness	-.23**	.32**	.23**	.14**
Conscientiousness	-.16**	.18**	.25**	.05
Neuroticism	.11*	-.17**	-.13**	-.04
Openness	-.02	.22**	.03	.02
<u>Moral Foundations</u>				
Harm	.04	.19**	.22**	.30**
Ingroup	-.04	.12*	.23**	.08
Authority	-.02	.06	.23**	.10
Purity	-.04	.14**	.28**	.14**

* $p < 0.05$, ** $p < 0.01$

3.4. ADDITIONAL FINDINGS

Since this is the first study using the Turkish version of GASP, the associations between GASP scores and demographic characteristics were additionally examined.

In order to investigate whether participants' age and scores for each subscale were associated, a correlation analyses were conducted. Results of the Pearson correlation revealed that as participants' age increased, their scores for guilt NBE ($r = .29$, $p < .01$), guilt repair ($r = .20$, $p < .01$), and shame NSE ($r = .14$, $p < .01$) subscales also increased. In other words, as their age increased, their tendency to make negative evaluations on their behavior and on the self as well as their reparative action tendencies following transgression increased. However, shame withdraw showed a distinct pattern in its relationship with age. A negative

association was found between participants' score of shame withdraw subscale and their age ($r = -.15, p < .01$). The tendency to withdraw decreased as participants' age increased.

In order to investigate whether gender has an effect on the subscale scores of the participants, considering that the subscales were correlated with each other, a MANOVA with gender as the factor and all four subscale scores as dependent variables was conducted. Before conducting MANOVA, in order to balance the number of female and male participants, the data of 99 female participants were randomly selected and included in the analysis. Box's Test of Equality of Covariance Matrices revealed that the assumption of homogeneity of covariance across groups was met ($p > .001$). However, the assumption of equal variances of each variable across the groups was not met for shame NSE and guilt NBE subscales indicated by the significant values for Levene's Test of Equality of Error Variances ($p < .05$). Lastly, the assumption of multicollinearity was not met, since shame withdraw subscale did not correlate with guilt related subscales. Since all assumptions of MANOVA were not met, four separate independent-samples t-tests were conducted instead. The results revealed a significant difference in mean scores of men and women only for guilt NBE subscale, $t(187) = 2.96, p = .003$. Levene's test indicated unequal variances ($F = 8.35, p = .004$), therefore degrees of freedom were adjusted from 196 to 187. Scores for guilt NBE were higher for women ($M = 17.51, SD = 3.49$) than for men ($M = 15.84, SD = 4.38$).

DISCUSSION

The goal of the present study was to adapt Guilt and Shame Proneness Scale to Turkish and evaluate its psychometric properties. Initially a confirmatory factor analysis was conducted, and results revealed that original model suggested by the authors had a poor fit in our sample, and reliability coefficients for each subscale showed poor internal consistency. Following Cohen et al.'s approach (2011), which is to reach internally reliable subscales, exploratory and

confirmatory factor analyses were carried out and the findings were inspected in coordination with the match between the original subscales and the factor structure of this study. Based on the analyses' results, the original model showed an acceptable fit, and Guilt NBE and guilt repair subscales were confirmed in this sample, though they showed relatively low reliability. For the shame NSE and shame withdraw subscales the present study failed to provide evidence indicating that they are reliable and valid measures for this sample. In this section, first the possible reasons for the elimination of certain items will be discussed. Next, the final factor composition and correlations among subscales and other measures will be reviewed in light of the previous literature.

Based on the results of all exploratory and confirmatory factor analyses, 6 items in total were excluded from the Turkish version of the scale.

Items 1 (After realizing you have received too much change at a store, you decide to keep it because the salesclerk doesn't notice. What is the likelihood that you would feel uncomfortable about keeping the money?) and 3 (You rip an article out of a journal in the library and take it with you. Your teacher discovers what you did and tells the librarian and your entire class. What is the likelihood that this would make you would feel like a bad person?) were excluded due to their problematic distribution in the sample. Both items had quite high means and skewed distributions that the acts invariably produced high likelihood of feeling guilt or shame. Both items refer to the situations each of which might be regarded as a form of stealing. High mean values point to the possibility that these scenarios which include stealing might elicit strong emotional reactions in the participants, leading to the failure of these two items in distinguishing participants from one another.

Item 2 (You are privately informed that you are the only one in your group that did not make the honor society because you skipped too many days of school. What is the likelihood that this would lead you to become more responsible about attending school?) was excluded due to its low loading to the factor representing guilt repair subscale in the Turkish form. Item 2 in the original scale refers to "honor society", which is an organization equivalent of which does not exist in

Turkish culture. Although in the translation process of the scale to Turkish, we replaced “being a member of honor society” with “being an honor student,” in an attempt to adapt this scenario to the culture, our attempt might have failed. Being a member of the honor society is more prestigious and provide greater gains for the person who achieves to be a member compared to being an honor student in Turkey. Considering the mean score of this item among other guilt-repair items is the lowest, perhaps failing to be an honor student might not be perceived as a failure as much as other scenarios in this sample.

Item 7 (A friend tells you that you boast a great deal. What is the likelihood that you would stop spending time with that friend?) and Item 12 (You take office supplies home for personal use and are caught by your boss. What is the likelihood that this would lead you to quit your job?) were excluded from shame withdraw subscale. When these extracted items and those that remained in the subscale (Item 4 and Item 8) are inspected, it can be seen that Items 4 (After making a big mistake on an important project at work in which people were depending on you, your boss criticizes you in front of your coworkers. What is the likelihood that you would feign sickness and leave work?) and Item 8 (Your home is very messy and unexpected guests knock on your door and invite themselves in. What is the likelihood that you would avoid the guests until they leave?) ask participants to rate not only their likelihood of withdrawing themselves from a shame inducing situation, but also their likelihood of doing that even that means committing another misdeed. To illustrate, item 4 asks participants not only the likelihood of leaving work after being criticized by their boss for the mistake they did, but also the likelihood of feigning sickness to leave work, which might be considered another misdeed. Similarly, item 8 asks participants the likelihood of avoding their guests who came to visit when their home was messy. Especially in Turkish culture, which is known for its hospitality, avoiding guests might be considered as a culturally wrong behavior. Therefore, scores for these two items might implicate not only a withdrawal tendency related to shame feelings, but also the likelihood of engaging in another morally wrong behavior. The behaviors representing withdrawal action tendencies described in remaining two items, on

the other hand, do not include another transgression inherent in themselves. This difference might be a possible explanation why those two sets of items were not perceived as belonging to the same factor by participants in the present study/forming one factor together.

Furthermore, based on the initial exploratory factor analysis, the highest factor loadings of item 7 and item 12 belonged to shame NSE and guilt NBE respectively. Since Item 7 is the only item among others in the original shame withdraw subscale, which includes a negative evaluation of the self by others, participants might have perceived it belonging to shame NSE rather than shame withdraw subscale. Similarly, item 12 seems to be perceived by participants as belonging to guilt NBE factor as indicated by factor analysis, and when included in the shame withdraw subscale in the model tested, it loaded to it in a different direction than other items. Taken together these two findings, it could be argued that item 12 might have been perceived by the participants as representing guilt-related self punishment instead of shame related withdrawal action tendency.

In the original scale, self versus behavior, and public versus private distinctions were applied to the items that form shame NSE and guilt NBE subscales; however, shame withdrawal and guilt repair subscales were differentiated only on the basis of whether the transgression was publicly exposed or committed in private. Cohen et al. (2011) also admitted that shame feelings might be experienced in private transgressions, and guilt might be elicited when transgression was publicly exposed. The items of the subscales measuring behavioral tendency (shame withdraw and guilt repair) do not provide information about whether participants attribute their negative evaluations to their behavior or to the self. Therefore, it is not clear whether guilt or shame underlies withdrawal action tendencies and repair action orientations, described in the scenarios of the scale. Nelissen (2012) hypothesized that self punishment following transgressions serves an adaptive function of guarding interpersonal relations by communicating the feeling of remorse and provide empirical support for his hypothesis. Self-punishment is also a likely response to guilt when repairing the harm done is not possible, that is when self punishment is the only way to display feelings of

remorse (Nelissen & Zeelenberg, 2009). Tanaka, Yagi, Komiya, Mifune, and Ohtsubo (2015) also proposed that shame induced self-punishment might also be adaptive since it renders the possibility of maintaining one's reputation following transgression. This might be a possible explanation for item 12's loading to the shame withdraw factor in an opposite direction than other items. Quitting the job after caught using office supplies for personal use whether it be shame or guilt induced might be perceived as an opportunity to repair the transgression by signaling feelings of remorse, though it is a costly opportunity.

Items in the original scale which form shame NSE and shame withdraw subscales did not work and failed to capture shame proneness in the present study, given that shame related subscales remained with two items each and showed poor reliability. One possible explanation might be the fact that scenarios in the scale may not be relevant for capturing shame proneness in Turkish culture. Indeed, Leeming and Boyle (2004) refer to this as a major disadvantage of all scenario-based measures, indicating that scenarios in a scale developed in a culture may not be relevant to the other cultures. The need for identifying themes specific to a culture that induce shame was uttered by Tangney & Dearing (2002). In fact, Çağın (2014) based on her study which explored culture specific themes that trigger shame for Turkish culture reported that in response to moral transgressions guilt accompanied shame while being exposed to sexual stimuli in public was the only condition that captures pure shame experience in Turkish culture. It is possible that shame NSE items of GASP include scenarios which make it difficult to separate shame from guilt for Turkish culture, given that scenarios of GASP resemble situations classified as moral transgressions in Çağın's study (2014). To exemplify, item 10 (You successfully exaggerate your damages in a lawsuit. Months later, your lies are discovered, and you are charged with perjury. What is the likelihood that you would think you are a despicable human being?) representing shame NSE subscale describes a legal condition in which the person is charged with perjury. It is more likely that both shame and guilt are elicited in this scenario, which makes it difficult to differentiate the two emotions.

In line with the original study, guilt subscales and shame NSE correlated significantly to each other in the present study. Though Cohen et al. (2011) reported a positive correlation in small magnitude between shame NSE and shame withdraw subscale, there was no statistically significant association between the two in the present study. Shame withdraw correlated only negatively with guilt NBE subscale as it did in the original study. Given that the two items in shame withdraw subscale in the present study seem to assess also the likelihood of committing another transgression at least for this sample, the lack of association between shame subscales is not surprising. Indeed, based on their study findings Cohen et al. (2011) also suggested to remove the label of shame from the withdraw subscale by stating that items of shame withdraw measures a maladaptive action tendency, and not emotional proneness to experience shame as a moral emotion.

Although the internal reliability of all subscales of Turkish version of GASP was found to be low, the results of the correlational analyses between GASP, and other theoretically related variables are in general consistent with the literature. In the present study, guilt subscales were found to be positively associated with adaptive and prosocial personality traits like agreeableness, and conscientiousness; whereas shame withdraw subscale was negatively associated to those constructs, and again in line with the literature, shame withdraw was found to be positively associated with neuroticism (Cohen et al., 2011; Erden & Akbağ, 2015; Wolf et al., 2010). Furthermore, openness and extraversion personality dimensions were found to be positively associated with guilt repair and guilt NBE respectively. This distinct pattern of relationship might be considered as an evidence indicating the distinctiveness of the guilt NBE and guilt repair subscales.

In relation to aggression, Guilt NBE, guilt repair, and shame NSE negatively correlated with all forms of aggression, while shame withdraw correlated positively with hostility and indirect aggression. Guilt prone individuals are reported to be both less likely to experience anger and less likely to engage in aggressive behaviors in dealing with anger in the literature (Stuewig et al., 2010; Tangney & Dearing, 2002). These findings of the present study are consistent

with the previous literature and the original study that reported significant negative correlations between guilt related subscales and anger, hostility, physical, and verbal aggression (Cohen et al., 2011), which provide evidence for the validity of the guilt related subscales in the Turkish version.

In relation to moral foundations, Shame NSE was found to be associated positively with only purity and harm, while no association was found between shame withdraw and any of the moral concerns. On the other hand, Guilt NBE and guilt repair subscales correlated positively with harm, ingroup, and purity moral concerns. Their pattern of relationship to moral concerns differed only for authority moral concern. While guilt NBE was found to be associated positively with authority moral concern, no association was found between authority and guilt repair subscale. This distinct pattern of relationship to authority moral concern indicates that though they share similarity, guilt NBE and guilt repair subscales measure two separate constructs as suggested by Cohen et al. (2011). Furthermore, given that ingroup, purity, and harm moral concerns are associated with empathic concern (Rebega, 2017), and empathic concern is linked to the capacity to experience guilt, our findings supports the validity of the guilt subscales.

In relation to the effect of age in guilt proneness, the present study revealed that there was a positive association between the age of participants and their guilt NBE, guilt repair and shame NSE scores, while shame withdraw subscale was found to be negatively associated with participants' age. Our finding that guilt proneness both in the form of tendency to make negative evaluations and of tendency for reparative actions increases with age is consistent with the result of the study conducted by Rebega (2017), which showed the generation effect on guilt proneness. Similarly, in a study conducted by Orth, Robins, and Soto (2010) using cross-sectional data, it has been found that guilt proneness increased with age. Also, they reported that shame proneness showed a decrease in the period between adolescence and middle age, and an increase after the age of fifty. They evaluated their findings with regard to maturity principle, implication of which for shame and guilt is that as individuals get older, their guilt proneness

should increase while their proneness to shame should decrease since the first is considered as adaptive emotion, and the latter as maladaptive (Orth, Robins, & Soto, 2010). From the perspective of maturity principle, our finding that while guilt NBE, guilt repair, and shame NSE increases with age, shame withdraw decreases is consistent with Cohen et al.'s suggestion that shame NSE assesses adaptive aspect of shame, while shame withdraw captures maladaptive aspect of shame (2011).

As to the effect of gender on guilt and shame proneness, present study revealed that gender had an effect on only making negative evaluations on the behavior following transgressions. The finding that women scored higher than men for guilt NBE subscale is in line with the literature showing that women are more prone to guilt than men (Cohen et al., 2011; Rebege, 2017; Silfver, Helkama, Lönnqvist, & Verkasalo, 2008; Tangney & Dearing, 2002), which seems to support the validity of the guilt NBE subscale.

4.1. LIMITATIONS AND SUGGESTIONS FOR FUTURE RESEARCH

Although a sample as large and representative as possible was aimed in this research, after exclusion of some participants' data, our sample size was slightly above the minimum number of participants suggested for conducting exploratory and confirmatory analyses. Future studies should be conducted with larger and more representative samples.

Another limitation of the present study was that frequency of female and male participants was divergent. A sample, that provides more equal distribution of male and female participants would render the possibility of comparing men and women in terms of their proneness to shame and guilt.

Considering that whether any action is perceived as morally wrong or not may vary across cultures, developing a scenario-based measure, transgressions scenarios of which are collected from Turkish sample instead of attempting to adapt an existing one would also be an important direction for future research. Based on the result of the present study, it can be said that guilt subscales are

promising at measuring guilt proneness in Turkish culture as well. Through future studies, guilt subscales might be improved in terms of their reliability with the addition of items, scenarios of which would be collected from a Turkish sample. For shame subscales, on the other hand, developing a subscale measuring shame related withdrawal tendency not confounded by the tendency to commit another transgression seems to be required in order to better understand the explanatory role of withdrawal tendency on the maladaptive side of shame.

Lastly, with regard to further understand the adaptive and maladaptive functions of different dimensions of shame and guilt, the relationship between the level of personality organization and proneness to shame and guilt seems to be worth exploring in future studies.

CONCLUSION

The present study indicate that guilt subscales of GASP are promising at measuring the tendency to make negative evaluations of behavior and reparative action tendencies following transgressions. On the other hand, the shame subscales of GASP as reliable measures, thus the premise of the scale to be able to differentiate guilt and shame, were not supported for the Turkish version. Yet, the shame subscales seem to capture significant expected associations that warrant further research.

References

- Ahmed, E., & Braithwaite, V. (2004). "What, me ashamed?" Shame management and school bullying. *Journal of Research in Crime and delinquency*, 41(3), 269-294.
- Akhtar, S. (Ed.). (2015). *Shame: Developmental, Cultural, and Clinical Realms*. Karnac Books.
- Ausubel, D. P. (1955). Relationships between shame and guilt in the socializing process. *Psychological Review*, 62, 378-390.
- Barrett, K. C. (1995). A functionalist approach to shame and guilt. In J. P. Tangney & Fisher (Ed.) *Self-conscious emotions: The psychology of shame, guilt, embarrassment, and pride* (pp. 25-63). New York, NY, US: Guilford Press.
- Baumeister, R. F., Stillwell, A. M., & Heatherton, T. F. (1994). Guilt: an interpersonal approach. *Psychological bulletin*, 115(2), 243
- Benedict, R. (1946). *The Chrysanthemum and the sword*. Houghton-Mifflin, New York, NY.
- Blair , R. J., Budhani , S. Colledge , E., & Scott, S. (2005). Deafness to fear in boys with psychopathic tendencies. *Journal of Child Psychology & Psychiatry*, 46, 327-336.
- Bugay, A., & Demir, A. (2011). Psychometric Properties of the Turkish Version of Trait Shame and Guilt Scale. *Eurasian Journal of Educational Research (EJER)*, (45).
- Buss, A. H. & Durkee, A. (1957). An inventory for assessing different kinds of hostility in clinical situations. *Journal of Consulting Psychology*, 21, 343-348.

- Buss, A. H., & Perry, M. (1992). The aggression questionnaire. *Journal of Personality and Social Psychology*, *63*, 452-459.
- Buss, A. H. & Warren, W. L. (2000). *The aggression questionnaire manual*. Los Angeles: Western Psychological Services.
- Bybee, J., Zigler, E., Berliner, D., & Merisca, R. (1996). Guilt, guilt-evoking events, depression, and eating disorders. *Current Psychology*, *15*(2), 113-127.
- Can, S. (2002). Validity and reliability of the scale called 'Aggression Questionnaire' in Turkish population (Unpublished Dissertation Thesis). GATA Haydarpaşa Eğitim Hastanesi, İstanbul.
- Carni, S., Petrocchi, N., Del Miglio, C., Mancini, F., & Couyoumdjian, A. (2013). Intrapsychic and interpersonal guilt: a critical review of the recent literature. *Cognitive Processing*, *14*(4), 333-346.
- Cohen, T. R., Wolf, S. T., Panter, A. T., & Insko, C. A. (2011). Introducing the GASP scale: A measure of guilt and shame proneness. *Journal of Personality and Social Psychology*, *100*, 947- 966.
- Combs, D. J. Y., Campbell, G., Jackson, M. & Smith, R. H. (2010). Exploring the consequences of humiliating a moral transgressor. *Basic and Applied Social Psychology*, *32*, 128-143.
- Cook, D. R. (1989). *Internalized Shame Scale (ISS)*. University of Wisconsin, Stout.
- Campos, J. J., Mumme, D., Kermoian, R., & Campos, R. G. (1994). A functionalist perspective on the nature of emotion. *Japanese Journal of Research on Emotions*, *2*(1), 1-20.
- Çağın, Ö. (2014). Exploring shame as a relationally-conscious emotion (Unpublished Dissertation Thesis). Boğaziçi Üniversitesi, İstanbul.

- De Hooge, I. E., Zeelenberg, M., & Breugelmans, S. M. (2007). Moral sentiments and cooperation: Differential influences of shame and guilt. *Cognition and emotion*, *21*(5), 1025-1042.
- De Hooge, I. E., Zeelenberg, M., & Breugelmans, S. M. (2010). Restore and protect motivations following shame. *Cognition & Emotion*, *24*, 111-127.
- De Hooge, I. E., Zeelenberg, M., & Breugelmans, S. M. (2011). A functionalist account of shame-induced behaviour. *Cognition & emotion*, *25*(5), 939-946.
- Dunn, P. K., & Ondercin, P. (1981). Personality variables related to compulsive eating in college women. *Journal of Clinical Psychology*, *37*(1), 43-49.
- Ekman, P., & Cordaro, D. (2011). What is meant by calling emotions basic. *Emotion review*, *3*(4), 364-370.
- Erden, S., & Akbağ, M. (2015). How do personality traits effect shame and guilt?: An evaluation of the Turkish culture. *Eurasian Journal of Educational Research*, *58*, 113-132.
- Erikson, E. H. (1950). *Childhood and society*. New York: Norton.
- Fairburn, C. G. & Cooper, P. J. (1984). Binge-eating, self-induced vomiting and laxative abuse: A community study. *Psychological Medicine*, *14*(2), 401-410.
- Fedewa, B. A., Burns, L. R., & Gomez, A. A. (2005). Positive and negative perfectionism and the shame/guilt distinction: adaptive and maladaptive characteristics. *Personality and Individual Differences*, *38*, 1609-1619.
- Fontaine, J. R. J., Luyten, P., De Boeck, P., & Corveleyn, J. (2001). The Test of Self-conscious Affect: Internal Structure, Differential Scales and Relationships with Long-term Affects. *European Journal of Personality*, *15*, 449-463.

- Freud, S. (1953b). Three essays on the theory of sexuality, In J. Strachey (Ed. & Trans.) *The standard edition of the complete psychological works of Sigmund Freud* (pp. 73-102). London: Hogarth Press. (Original work published 1914).
- Freud, S. (1957). On Narcissism: An introduction. In Strachey (Ed. & Trans.) *The standard edition of the complete psychological works of Sigmund Freud* (pp. 173-182). London: Hogarth Press. (Original work published 1924).
- Freud, S. (1961a). Civilization and its discontents. In J. Strachey (Ed. & Trans.) *The standard edition of the complete psychological works of Sigmund Freud* (pp. 57-146). London: Hogarth Press. (Original work published 1930).
- Freud, S. (1961). Some physical consequences of the anatomical distinction between the sexes. In J. Strachey (Ed.), *The standard edition of the complete psychological works of Sigmund Freud* (Vol. 19). London: Hogarth Press. (Originally published 1925)
- Freud, S. (1961c). The dissolution of the Oedipus Complex. In Strachey (Ed. & Trans.) *The standard edition of the complete psychological works of Sigmund Freud* (pp. 173-182). London: Hogarth Press. (Original work published 1924).
- Freud, S. (1961d). The id and the ego. In Strachey (Ed. & Trans.) *The standard edition of the complete psychological works of Sigmund Freud* (pp. 12-66). London: Hogarth Press. (Original work published 1923).
- Gausel, N., & Leach, C. W. (2011). Concern for self-image and social image in the management of moral failure: Rethinking shame. *European Journal of Social Psychology, 41*, 468-478.
- Gausel, N. (2012). Facing in-group mortality: Differentiating expressed shame from expressed guilt. *Review of European Studies, 4*, 1-7.

- George, D., & Mallery, P. (2010). *SPSS for Windows step by step. A simple study guide and reference* (10th ed.). New York: Pearson.
- Graham, J., Nosek, B. A., Haidt, J., Iyer, R., Koleva, S., & Ditto, P. H. (2011). Mapping the moral Domain. *Journal of personality and social psychology*, *101*(2), 366.
- Guilt. (n.d.). In *Merriam-Webster Online Dictionary*. Retrieved from <https://www.merriam-webster.com/dictionary/guilt>
- Harder, D. W., & Lewis, S. J. (1987). The assessment of shame and guilt. *Advances in personality assessment*, *6*, 89-114.
- Harder, D. W., Cutler, L., & Rockart, L. (1992). Assessment of Shame and Guilt and Their Relationships to Psychopathology. *Journal of Personality Assessment*, *59*(3), 584-604.
- Harris, C. R., & Darby, R. S. (2009). Shame in physician-patient interactions: Patient perspectives. *Basic and Applied Social Psychology*, *31*(4), 325-334.
- Hartmann, H. & Loewenstein, R. (1962). Notes on the superego. *Psychoanalytic Study of the Child*, *17*, 42-81.
- Hoffman, M. L. (1982). Development of Prosocial Motivation: Empathy and Guilt. In N. Eisenberg (Ed) *The development of prosocial behavior* (281-313). New York: Academic Press.
- Howell, A. J., Turowski, J. B., & Buro, K. (2012). Guilt, empathy, and apology. *Personality and Individual Differences*, *53*(7), 917-922.
- Inbar, Y., Pizarro, D. A., Gilovich, T., & Ariely, D. (2013). Moral masochism: On the connection between guilt and self-punishment. *Emotion*, *13*, 14-18.

- John, O. P., Donahue, E. M. & Kentle, R. L. (1991). The Big Five Inventory – Versions 4a and 54. University of California, Berkeley, Institute of Personality and Social Research.
- Joireman, J. (2004). Empathy and the self-absorption paradox II: self rumination and self-reflection as mediators between shame, guilt, and empathy. *Self and Identity*, 3(3), 225-238.
- Karaman, N. G., Dogan, T., & Coban, A. E. (2010). A study to adapt the big five inventory to Turkish. *Procedia-Social and Behavioral Sciences*, 2(2), 2357-2359.
- Keltner, D., & Harker, L. (1998). The forms and functions of the nonverbal signal of shame. In P. Gilbert (Ed.) *Shame: Interpersonal behavior, psychopathology, and culture* (pp. 78–98). New York: Oxford University Press.
- Kemeny, M. E., Gruenewald, T. L., & Dickerson, S. (2004). Shame as the emotional response to threat to the social self: Implications for behavior, physiology, and health. *Psychological Inquiry*, 15, 153–160.
- Ketelaar, T., & Tung Au, W. (2003). The effects of feelings of guilt on the behavior of uncooperative in repeated social bargaining games: An affect-as-information interpretation of the role of emotion in social interaction. *Cognition and emotion*, 17(3), 429-453.
- Klein, M. (1945). The oedipus complex in the light of early anxieties. *The International Journal of Psychoanalysis*, 26, 11-33.
- Kohut, H. (1966). Forms and transformations of narcissism. *Journal of the American Psychoanalytic association*, 14(2), 243-272.
- Kohut, H. (1971). *The Analysis of the Self*. New York: International Universities Press.

- Kohut, H. (1977). *The Restoration of the Self*. New York: International Universities Press.
- Kohut, H. (1978). *The search for the self*. New York: International Universities Press.
- Kroll, J., & Egan, E. (2004). Psychiatry, moral worry, and moral emotions. *Journal of Psychiatric Practice, 10*, 352–360.
- Kugler, K., & Jones, W. H. (1992). On conceptualizing and assessing guilt. *Journal of Personality and Social Psychology, 62*, 318–327.
- Lansky, M. R., & Morrison, A. P. (1997). The legacy of Freud's writings on shame. In M. R. Lansky & A. P. Morrison (Eds.), *The Widening Scope of Shame* (pp. 3-40). Hillsdale, NJ: Analytic Press.
- Lansky, M. (2005). Hidden Shame. *Journal of the American Psychoanalytic Association, 53*(3), 865-890.
- Leeming, D., & Boyle, M. (2004). Shame as a social phenomenon: A critical analysis of the concept of dispositional shame. *Psychology and Psychotherapy: Theory, Research & Practice, 77*, (3), 375-396.
- Leith, K. P., & Baumeister, R. F. (1998). Empathy, shame, guilt, and narratives of interpersonal conflicts: Guilt prone people are better at perspective taking. *Journal of personality, 66*(1), 1-37.
- Malti, T. (2016). Toward an integrated clinical-developmental model of guilt. *Developmental Review, 39*, 16-36.
- Martenz, W. (2005). A Multicomponential Model of Shame. *Journal for the Theory of Social Behavior, 35*(4), 399-411.
- Miceli, M. & Castelfranchi, C. (2018). Reconsidering the difference between shame and guilt. *Europe's Journal of Psychology, 14*(3), 710-733.

- Michl, P., Meindl, T., Meister, F., Born, C., Engel, R. R., Reiser, M., & Hennig-Fast, K. (2012). Neurobiological underpinnings of shame and guilt: A pilot fMRI study. *Social Cognitive and Affective Neuroscience*, 9(2), 150-157.
- Mitchell, S. A., & Black, M. J. (1995). *Freud and beyond: A history of modern psychoanalytic thought*. New York: Basic Books.
- Mollon, P. (2005). The inherent shame of sexuality. *British Journal of Psychotherapy*, 22(2), 167-178.
- Morrison, A. P. (1983). Shame, ideal self, and narcissism. *Contemporary Psychoanalysis*, 19(2), 295-318.
- Morrison, A. P. (2014). *Shame: The underside of narcissism*. Routledge.
- Motan, I. (2007). Recognition of self-conscious emotions in relation to psychopathology (Unpublished master's thesis). Middle East Technical University, Ankara.
- Murray, C., Waller, G., & Legg, C. (2000). Family dysfunction and bulimic psychopathology: The mediating role of shame. *International Journal of Eating Disorders*, 28(1), 84-89.
- Nelissen, R., & Zeelenberg, M. (2009). When guilt evokes self-punishment: evidence for the existence of a Dobby Effect. *Emotion*, 9(1), 118.
- Nelissen, R. M. (2012). Guilt-induced self-punishment as a sign of remorse. *Social Psychological and Personality Science*, 3(2), 139-144.
- Orth, U., Berking, M., & Burkhardt, S. (2006). Self-conscious Emotions and Depression: Rumination Explains Why Shame but not Guilt is Maladaptive. *Personality and Social Psychology Bulletin*, 32(12), 1608-1619.

- Orth, U., Robins, R. W., & Soto, C. J. (2010). Tracking the trajectory of shame, guilt, and pride across the life span. *Journal of personality and social psychology*, 99(6), 1061.
- Panken, S. (1983). *The joy of suffering: psychoanalytic theory and therapy of masochism*. Jason Aronson, Northvale.
- Pineles, S. L., Street, A. S., & Koenen, K. C. (2006). The Differential Relationships of Shame-proneness and Guilt-proneness to Psychological and Somatization Symptoms. *Journal of Social and Clinical Psychology*, 25(6), 688-704.
- Piers, G. & Singer, M. (1971). Shame and guilt: a psychoanalytic and a cultural study. New York: W. W. Norton. (Original work published 1953).
- Quiles, Z. N. & Bybee, J. (1997). Chronic and Dispositional Guilt: Relations to Mental Health, Prosocial Behavior, and Religiosity. *Journal of Personality Assessment*, 69, 104-126.
- Rebega, O. L. (2017). Gender differences in moral concerns, guilt and shame proness, and empathy. *Romanian Journal of Experimental Applied Psychology*, 8, 130-135.
- Rebega, O. L. (2017). The generational gap: investigating differences and associations between moral intuitions, fear of negative evaluations and guilt and shame proneness. *Romanian Journal of Experimental Applied Psychology*, 8, 136-142.
- Roberts, W., Strayer, J., & Denham, S. (2014). Empathy, anger, guilt: Emotions and prosocial behaviour. *Canadian Journal of Behavioural Science/Revue canadienne des sciences du comportement*, 46(4), 465.
- Rohleder, N., Chen, E., Wolf, J. M., & Miller, G. E. (2008). The psychobiology of trait shame in young women: Extending the Social-Self Preservation Theory. *Health Psychology*, 27, 523-532.

- Sarıçam, H., Akın, A. & Çardak, M. (2012, September 19-21). Hatayla ilişkili utanç ve suçluluk duygusu ölçeği türkçe formunun geçerlik ve güvenilirlik çalışması. Paper presented at 3rd National Congress on Assessment and Evaluation in Education and Psychology, Abant İzzet Baysal University, Bolu.
- Şahin, N. H., & Şahin, N. (1992). Adolescent guilt, shame, and depression in relation to sociotropy and autonomy. In *The World Congress of Cognitive Therapy*, Toronto (pp. 17-21).
- Schmader, T. & Lickel, B. (2006). The approach and avoidance function of guilt and shame emotions: Comparing reactions to self-caused and other-caused wrongdoing. *Motivation and Emotion*, 30(1), 43-56.
- Shame. (n.d.). In *Merriam-Webster Online Dictionary*. Retrieved from <https://www.merriam-webster.com/dictionary/shame>
- Sheikh, S., & Janoff-Bulman, R. (2010). The “shoulds” and “should nots” of moral emotions: A self-regulatory perspective on shame and guilt. *Personality and Social Psychology Bulletin*, 36(2), 213-224.
- Silfver, M., Helkama, K., Lönnqvist, J., & Verkasalo, M. (2008). The relation between value priorities and proneness to guilt, shame, and empathy. *Motivation and Emotion*, 32, 69-80.
- Schore, A. N. (1991). Early superego development: The emergence of shame and narcissistic affect regulation in the practicing period. *Psychoanalysis and Contemporary Thought*, 14(2), 187-250.
- Smith, R. H., Webster, J. M., Parrott, W. G., & Eyre, H. L. (2002). The role of public exposure in moral and nonmoral shame and guilt. *Journal of Personality and Social Psychology*, 83,138-159.
- Stuewig, J., Tangney, J. P., Heigel, C., Harty, L., & McCloskey, L. (2010). Shaming, blaming, and maiming: Functional links among the moral

- emotions, externalization of blame, and aggression. *Journal of Research in Personality*, *44*(1), 91-102.
- Stuewig, J., Tangney, J. P., Kendall, S., Folk, J. B., Meyer, C. R., & Dearing, R. L. (2015). Children's proneness to shame and guilt predict risky and illegal behaviors in young adulthood. *Child Psychiatry & Human Development*, *46*(2), 217-227.
- Tanaka, H., Yagi, A., Komiya, A., Mifune, N., & Ohtsubo, Y. (2015). Shame-prone people are more likely to punish themselves: A test of the reputation-maintenance explanation for self-punishment. *Evolutionary Behavioral Sciences*, *9*(1), 1-7.
- Tangney, J. P. (1991). Moral Affect: The Good, the Bad, and The Ugly. *Journal of Personality and Social Psychology*, *61*(4), 598-607.
- Tangney, J. P., Wagner, P., Fletcher, C., & Gramzow, R. (1992). Proneness to Shame, Proneness to Guilt, and Psychopathology. *Journal of Abnormal Psychology*, *101*(3), 496-478.
- Tangney, J. P. (1996). Conceptual and methodological issues in the assessment of shame and guilt. *Behaviour Research and Therapy*, *34*(9), 741-754.
- Tangney, J. P., Miller, R. S., Flicker, L., & Barlow, D. H. (1996). Are shame, guilt and embarrassment distinct emotions? *Journal of Personality and Social Psychology*, *70*, 1256-1269.
- Tangney, J. P., Dearing, R. L., Wagner, P. E., & Gramzow, R. H. (2000). The Test of Self-Conscious Affect – 3 (TOSCA-3). George Mason University, Fairfax, VA.
- Tangney, J. P., & Dearing, R. L. (2002). *Shame and guilt*. New York, NY, US: Guilford Press.
- Tangney, J. P., Stuewig, J., & Mashek, D. J. (2007). Moral emotions and moral behavior. *Annual Review of Psychology*, *58*, 345-372.

- Thrane, G. (1979), Shame and the construction of the self. *The Annual of Psychoanalysis*, 7, 321-341. New York: International Universities Press.
- Tignor, S. M., & Colvin, C. R. (2017). The Interpersonal Adaptiveness of Dispositional Guilt and Shame: A Meta-Analytic Investigation. *Journal of personality*, 85(3), 341-363.
- Tomkins, S. S. (1963). *Affect/imagery/consciousness. The negative affects*. New York: Springer.
- Tracy, J. L., & Robins, R. W. (2004). Putting the self into self-conscious emotions: A theoretical model. *Psychological Inquiry*, 15(2), 103-125.
- Tracy, J. L., Robins, R. W., & Tangney, J. P. (Eds.). (2007). The self-conscious emotions: *Theory and research*. Guilford Press.
- Lewis, H. B. (1971). *Shame and guilt in neurosis*. New York: International Universities Press.
- Winnicott, D. W. (1965). The maturational processes and the facilitating environment: Studies in the theory of emotional development. In *The Maturational Processes and the Facilitating Environment: Studies in the Theory of Emotional Development* (pp. 1-276). London: the Hogarth Press and the Institute of Psycho-analysis.
- Wolf, S. T., Cohen, T. R., Panter, A. T., & Insko, C. A. (2010). Shame proneness and guilt proneness: toward further understanding of reactions to public and private transgressions. *Self & Identity*, 9, 337-362.
- Wright, K., & Gudjonsson, G. H. (2007). The development of a scale for measuring offence-related feelings of shame and guilt. *Journal of Forensic Psychiatry Psychology*, 18(3), 307-316.
- Wurmser, L. (1981), *The Mask of Shame*. Baltimore, MD: Johns Hopkins University Press.

- Wurmser, L. (2015). Primary shame, mortal wound and tragic circularity: Some new reflections on shame and shame conflicts. *The International Journal of Psychoanalysis*, 96(6), 1615-1634.
- Yang, M. L., Yang, C. C., & Chiou, W. B. (2010). When guilt leads to other orientation and shame leads to egocentric self-focus: Effects of differential priming of negative affects on perspective taking. *Social Behavior and Personality: an international journal*, 38(5), 605-614.
- Yilmaz, O., Harma, M., & Bahçekapili, H. G., & Cesur, S. (2016). Validation of the moral foundations questionnaire in Turkey and its relation to cultural schemas of individualism and collectivism. *Personality and Individual Differences*, 99, 149–154.
- Zahn-Waxler, C., & Kochanska, G. (1990). The Origins of Guilt in Children. In R. A. Thompson (Ed.), *Nebraska Symposium on Motivation, 1988: Socioemotional Development* (pp. 183-258). Lincoln: University of Nebraska Press.

APPENDICES

Appendix A

Informed Consent Form

(In Turkish)

Bilgilendirilmiş Onam Formu

Sayın Katılımcı,

Bu araştırma, tez çalışması kapsamında İstanbul Bilgi Üniversitesi Klinik Psikoloji Yüksek Lisans Programı Yetişkin alt dalı öğrencisi Didem Topçu tarafından Dr. Öğretim Üyesi Alev Çavdar danışmanlığında yürütülmektedir. Araştırmanın amacı bazı duyguları deneyimleme eğilimini ölçen bir ölçeği Türkçeye uyarlamaktır.

Araştırmaya 18 yaşından büyük bireyler katılabilmektedir. Katılım tamamen gönüllülük esasına dayanmaktadır. Araştırmada sizden herhangi bir kimlik bilgisi istenmeyecektir. Araştırma sırasında elde edilen bilgiler gizli tutulacak ve anonim olarak değerlendirilecektir. Her ne kadar araştırmada size yöneltilecek soruların herhangi bir rahatsızlık hissine yol açacağı öngörülme de, dilediğiniz zaman neden göstermeksizin çalışmaya devam etmeyebilirsiniz. Araştırmayı tamamlamak yaklaşık olarak 30 dakika sürmektedir. Çalışmanın güvenirliliği ve geçerliliği açısından katılımcıların kendilerine yöneltilen hiçbir soruyu boş bırakmamaları beklenmektedir.

Araştırmaya yönelik herhangi bir sorunuz olması halinde araştırmanın yürütücüsü Didem Topçu ile didem.topcu@bilgi.edu.net mail adresi üzerinden iletişime geçebilirsiniz.

Katılımcı olarak araştırmaya katkıda bulunduğunuz için teşekkürler.

- Yukarıdaki açıklamayı okudum, bu koşullarda söz konusu araştırmaya katılmayı **kabul ediyorum.**
- Yukarıdaki açıklamayı okudum, bu koşullarda söz konusu araştırmaya katılmayı **kabul etmiyorum.**

Appendix B

Guilt and Shame Proneness Scale

(In English)

Instructions: In this questionnaire you will read about situations that people are likely to encounter in day-to-day life, followed by common reactions to those situations. As you read each scenario, try to imagine yourself in that situation. Then indicate the likelihood that you would react in the way described.

1	2	3	4	5	6	7
<i>Very Unlikely</i>	<i>Unlikely</i>	<i>Slightly Unlikely</i>	<i>About 50% Likely</i>	<i>Slightly Likely</i>	<i>Likely</i>	<i>Very Likely</i>

_____ 1. After realizing you have received too much change at a store, you decide to keep it because the salesclerk doesn't notice. What is the likelihood that you would feel uncomfortable about keeping the money?

_____ 2. You are privately informed that you are the only one in your group that did not make the honor society because you skipped too many days of school. What is the likelihood that this would lead you to become more responsible about attending school?

_____ 3. You rip an article out of a journal in the library and take it with you. Your teacher discovers what you did and tells the librarian and your entire class. What is the likelihood that this would make you would feel like a bad person?

_____ 4. After making a big mistake on an important project at work in which people were depending on you, your boss criticizes you in front of your coworkers. What is the likelihood that you would feign sickness and leave work?

_____ 5. You reveal a friend's secret, though your friend never finds out. What is the likelihood that your failure to keep the secret would lead you to exert extra effort to keep secrets in the future?

_____ 6. You give a bad presentation at work. Afterwards your boss tells your coworkers it was your fault that your company lost the contract. What is the likelihood that you would feel incompetent?

_____ 7. A friend tells you that you boast a great deal. What is the likelihood that you would stop spending time with that friend?

_____ 8. Your home is very messy and unexpected guests knock on your door and invite themselves in. What is the likelihood that you would avoid the guests until they leave?

_____ 9. You secretly commit a felony. What is the likelihood that you would feel remorse about breaking the law?

_____ 10. You successfully exaggerate your damages in a lawsuit. Months later, your lies are discovered and you are charged with perjury. What is the likelihood that you would think you are a despicable human being?

_____ 11. You strongly defend a point of view in a discussion, and though nobody was aware of it, you realize that you were wrong. What is the likelihood that this would make you think more carefully before you speak?

_____ 12. You take office supplies home for personal use and are caught by your boss. What is the likelihood that this would lead you to quit your job?

_____ 13. You make a mistake at work and find out a coworker is blamed for the error. Later, your coworker confronts you about your mistake. What is the likelihood that you would feel like a coward?

_____ 14. At a coworker's housewarming party, you spill red wine on their new cream-colored carpet. You cover the stain with a chair so that nobody notices

your mess. What is the likelihood that you would feel that the way you acted was pathetic?

_____ 15. While discussing a heated subject with friends, you suddenly realize you are shouting though nobody seems to notice. What is the likelihood that you would try to act more considerately toward your friends?

_____ 16. You lie to people but they never find out about it. What is the likelihood that you would feel terrible about the lies you told?

Appendix C

Utanç ve Suçluluk Eğilimi Ölçeği

(In Turkish)

Bu ankette insanların günlük yaşamlarında karşılaşması muhtemel olan bazı durumları ve bu durumlara verilen yaygın tepkileri okuyacaksınız. Her bir senaryoyu okurken kendinizi o durumda hayal etmeye çalışın. Daha sonra tarif edilen şekilde tepki verme olasılığınızı belirtin.

1 2 3 4 5 6 7

*Hiç olası
değil*

*Neredeyse yarı
yarıya olası*

*Tamamen
olası*

1. Bir dükkânda çok fazla para üstü almış olduğunuzu fark ettikten sonra kasiyer durumu fark etmediği için parayı geri vermemeye karar veriyorsunuz. Parayı geri vermemekle ilgili kendinizi rahatsız hissetme olasılığınız nedir?
2. Okulu birçok kez astığınızı için arkadaş grubunuzda onur öğrencisi olmayı başaramayan tek kişinin siz olduğunuz konusunda özel olarak bilgilendiriliyorsunuz. Bu durumun okula devam konusunda daha sorumluluk sahibi olmanıza yol açma olasılığı nedir?
3. Kütüphanedeki bir dergiden bir makaleyi koparıyorsunuz ve yanınızda götürüyorsunuz. Öğretmeniniz yaptığınızı fark edip kütüphane görevlisine ve tüm sınıfa bunu söylüyor. Bu olayın size kendinizi kötü biriymiş gibi hissettirme olasılığı nedir?
4. İşinizde insanların size bel bağlamış olduğu önemli bir projede büyük bir hata yaptıktan sonra, patronunuz çalışma arkadaşlarınızın önünde sizi eleştiriyor. Hasta numarası yapıp iş yerinden çıkıp gitme olasılığınız nedir?

5. Bir arkadaşınızın bir sırrını ifşa ediyorsunuz, gerçi arkadaşınız bu durumu asla öğrenmiyor. Bu sırrı tutmaktaki başarısızlığınızın gelecekte sır tutmak için fazladan çaba harcamanıza yol açma olasılığı nedir?
6. İş yerinde kötü bir sunum yapıyorsunuz. Sonrasında patronunuz çalışma arkadaşlarınıza şirketin sözleşmeyi kaybetmesinin sizin hatanız olduğunu söylüyor. Kendinizi yetersiz hissetme olasılığınız nedir?
7. Arkadaşınız size kendinizle çok fazla övündüğünüzü söylüyor. Bu arkadaşınızla vakit geçirmeyi bırakma olasılığınız nedir?
8. Eviniz çok dağınık ve beklenmedik misafirler kapınızı çalıp kendilerini içeri davet ettiriyorlar. Misafirler gidene kadar onlardan uzak durmaya çalışma olasılığınız nedir?
9. Ağır bir suçu gizlice işliyorsunuz. Yasaları çiğnemekle ilgili vicdan azabı duyma olasılığınız nedir?
10. Bir davada uğramış olduğunuz hasarı abartarak tazminat almayı başarıyorsunuz. Aylar sonra yalanlarınız ortaya çıkıyor ve yalan beyan vermekle suçlanıyorsunuz. Adi bir insan olduğunuzu düşünme olasılığınız nedir?
11. Bir tartışmada bir görüşü şiddetle savunuyorsunuz. Kimse farkında olmasa da siz yanıldığının farkına varıyorsunuz. Bu durumun konuşmadan önce daha dikkatlice düşünmenize yol açma olasılığı nedir?
12. Büro malzemelerini kişisel kullanımınız için eve getiriyorsunuz ve patronunuz tarafından yakalanıyorsunuz. Bu olayın işinizi bırakmanıza neden olma olasılığı nedir?

13. İş yerinde bir hata yapıyorsunuz ve bu hata için bir iş arkadaşınızın suçlandığını öğreniyorsunuz. Daha sonra iş arkadaşınız sizi hatanızla yüzleştiriyor. Korkak biriymiş gibi hissetme olasılığınız nedir?
14. Bir iş arkadaşınızın yeni taşındığı evde verdiği partide krem rengi yeni halısının üzerine kazayla kırmızı şarap döküyorsunuz. Sebep olduğunuz kirliliği kimse görmesin diye lekeyi bir sandalye ile kapatıyorsunuz. Davranış şeklinizin acınası olduğunu hissetme olasılığınız nedir?
15. Arkadaşlarınızla bir konuda hararetli bir şekilde tartışırken birdenbire kimse fark etmemiş görünse de, siz bağırıyor olduğunuzu fark ediyorsunuz. Arkadaşlarınıza karşı daha düşünceli davranmaya çalışma olasılığınız nedir?
16. İnsanlara yalan söylüyorsunuz, ancak bunu hiçbir zaman öğrenmiyorlar. Söylediğiniz yalanlarla ilgili çok kötü hissetme olasılığınız nedir?

Appendix D

Moral Foundations Scale (Part 1)

(In Turkish)

Ahlaki Temeller Ölçeği (1. Bölüm)

Bir şeyin doğru veya yanlış olup olmadığına karar vermenizde aşağıda verilen düşünceler ne derecede etkilidir? Lütfen cevaplarınızı aşağıdaki skalayı kullanarak derecelendiriniz.

0...hiç bir şekilde alakalı değildir (Bu düşünce doğru ve yanlış yargularıyla hiçbir şekilde alakalı değildir).

1...pek alakalı değildir

2...biraz alakalıdır

3...orta derecede alakalıdır

4...çok alakalıdır

5...kesinlikle alakalıdır (Bu düşünce bir şeyin doğru veya yanlış olduğuna karar verirken dikkat ettiğim en önemli faktörlerden biridir.)

1) Birisinin duygusal olarak acı çekip çekmediği	0	1	2	3	4	5
2) Birilerinin diğerlerine göre farklı muamele görüp görmediği	0	1	2	3	4	5
3) Birisinin eyleminin ülkesi için sevgi göstergesi olup olmadığı	0	1	2	3	4	5
4) Birisinin otoriteye saygısızlık edip etmediği	0	1	2	3	4	5
5) Birisinin namus ve edep konusundaki normları ihlal edip etmediği	0	1	2	3	4	5
6) Birisinin matematiğinin iyi olup olmadığı	0	1	2	3	4	5
7) Birisinin güçsüz ve incinebilir olan birini koruyup korumadığı	0	1	2	3	4	5
8) Birisinin adaletsiz davranıp davranmadığı	0	1	2	3	4	5
9) Birisinin grubuna ihanet edecek bir şey yapıp yapmadığı	0	1	2	3	4	5
10) Birisinin toplumun geleneklerine uyup uymadığı	0	1	2	3	4	5
11) Birisinin iğrenç bir şey yapıp yapmadığı	0	1	2	3	4	5
12) Birisinin zalim olup olmadığı	0	1	2	3	4	5
13) Birinin haklarının elinden alınmış olup olmadığı	0	1	2	3	4	5

14 Birisinin sadakatsizlik gösterip göstermediđi	0	1	2	3	4	5
15) Bir eylemin kaosa ya da düzensizliđe neden olup olmadıđı	0	1	2	3	4	5
16) Birisinin Tanrı'nın onaylayacađı bir şekilde davranıp davranmadıđı	0	1	2	3	4	5

Moral Foundations Questionnaire (Part 2)

(In Turkish)

Ahlaki Temeller Ölçeği (2. Bölüm)

Lütfen aşağıdaki cümleleri okuyunuz ve bunlara katılıp katılmadığınızı belirtiniz.

0...kesinlikle katılmıyorum

1...katılmıyorum

2...pek katılmıyorum

3...biraz katılıyorum

4...katılıyorum

5...kesinlikle katılıyorum

1) Acı çekenlere şefkat duyabilmek en önemli erdemdir.	0	1	2	3	4	5
2) Hükümet kanun yaparken teminat altına alınması gereken ilk kural herkese adil davranılmasıdır.	0	1	2	3	4	5
3) Ülkemin tarihiyle gurur duyarım.	0	1	2	3	4	5
4) Otoriteye saygı bütün çocukların öğrenmesi gereken bir şeydir	0	1	2	3	4	5
5) Hiç kimseye zarar vermese de insanlar iğrenç şeyler yapmamalıdır.	0	1	2	3	4	5
6) İyi olanı yapmak kötü olanı yapmaktan daha iyidir.	0	1	2	3	4	5
7) Birisinin yapabileceği en kötü şeylerden biri savunmasız bir hayvana zarar vermektir.	0	1	2	3	4	5
8) Adalet bir toplum için en önemli gereksinimdir.	0	1	2	3	4	5
9) İnsanlar. aile üyeleri yanlış bir şey yapmış olsa dahi onlara karşı sadık olmalıdırlar.	0	1	2	3	4	5
10) Erkeklerin ve kadınların toplum içinde farklı rolleri vardır.	0	1	2	3	4	5
11) Bazı hareketleri doğal olmadıkları için yanlış olarak nitelendiririm	0	1	2	3	4	5
12) Bir insanı öldürmek hiçbir zaman haklı bir hareket olamaz.	0	1	2	3	4	5
13) Bence fakir çocuklar miras olarak hiçbir şey alamazken zengin çocukların miras olarak çok para almaları ahlaki olarak yanlıştır.	0	1	2	3	4	5
14) Bir takım oyuncusu olmak birisinin kendisini bireysel olarak ifade etmesinden daha önemlidir.	0	1	2	3	4	5
15) Eğer bir asker olsaydım ve komutanımın emirleriyle aynı fikirde olmasaydım. yine de itaat ederdim çünkü bu benim görevimdir	0	1	2	3	4	5
16) İffet çok önemli ve değerli bir erdemdir.	0	1	2	3	4	5

Appendix E

Buss-Warren Aggression Questionnaire

(In Turkish)

Buss-Warren Agresyon Ölçeği

Aşağıdaki durumlar sizi ne kadar tanımlıyor?

	Karakterinize en uygun olan yanıtı (X) şeklinde işaretleyiniz	Hiç uygun değil	Çok az uygun	Biraz uygun	Çok uygun	Tam uygun
1	Arkadaşlarım çok münakaşacı olduğumu söyler					
2	Şans hep başkalarına gülüyor, hep onlardan yana oluyor					
3	Birden parlarım ama çabuk Sakinleşirim					
4	Kendimi sık sık diğer insanlarla tartışırken bulurum					
5	Bazen hayatın bana adaletli davranmadığını düşünürüm					
6	İnsanlarla aynı fikirde olmazsam onlarla tartışmaktan kendimi alı koyamam					
7	Bazen ortada hiçbir neden yokken Parlarım					
8	Kız ya da erkek birisi beni kışkırtırsa ona vurabilirim					
9	Bazen neden bu kadar katı olduğumu merak ediyorum					
10	Tanıdığım insanları tehdit ettiğim Olmuştur					

11	Biri çok üzerime geldiğinde, beni sıkıştırdığında ona vurabilirim					
12	Öfkemi kontrol etmekte zorluk çekerim					
13	Eğer çok kızarsam o kişinin yaptığı işleri berbat edebilirim					
14	Kapıyı arkadan gelenin yüzüne çarpacak kadar çıldırabilirim					
15	İnsanlar bana patronluk tasladıklarında onların inadına işi ağırdan alırım					
16	İnsanlar bana nazik davrandıklarında ne isteyeceklerini merak ederim					
17	Her şeyi dağıtacak kadar Çılgınlaşabilirim					
18	Bazen sevmediklerim hakkında dedikodu yayar, çamur atarım					
19	Ben sakın biriyim					
20	İnsanlar beni kızdıırırlarsa onlara gerçek düşüncelerimi söyleyebilirim					
21	Bazen insanların bana arkamdan güldüklerini hissedirim					
22	İstediğimi elde edemediğim zaman kızgınlığımı gösteririm					
23	Bazen birine vurma isteğimi kontrol Edemem					
24	Pek çok insandan daha sık kavga Ederim					
25	Eğer biri bana vurursa ben de ona Vururum					
26	Arkadaşlarımla aynı fikirde olmadığımda bunu açıkça söylerim					

27	Haklarımı korumak gerektiğinde şiddete başvurmam gerekirse hiç Çekinmem					
28	Fazla dostça davranan yabancılara Güvenmem					
29	Bazen kendimi patlamaya hazır bir bomba gibi hissedirim					
30	Beni gerçekten rahatsız edenlere susarak, ilgilenmeyerek tepki veririm					
31	Arkadaşlarımın arkamdan benim hakkımda konuştuklarını bilirim					
32	Bazı arkadaşlarım benim düşünmeden hareket ettiğimi söylerler					
33	Bazen hiçbir şeyi düşünemeyecek kadar kıskanç olurum					
34	El şakası yapmaktan hoşlanırım					

Appendix F

Big Five Inventory

(In Turkish)

Beş Faktörlü Kişilik Envanteri

Aşağıda verilen ifadelere ne ölçüde katıldığınızı lütfen belirtiniz.

	Tamamen Katlıyorum	Katlıyorum	Kararsızım	Katılmıyorum	Kesinlikle Katılmıyorum
1. Konuşkanım.					
2. İş yönelimliyim.					
3. Karamsarım.					
4. Orijinal, yeni fikirlere açığım.					
5. Çekingen biriyim.					
6. Yardımseverim biriyim.					
7. Biraz dikkatsiz olabilirim.					
8. Stresle iyi baş edebilen rahat biriyim.					
9. Birçok şeye meraklıyım.					
10. Enerji doluyum.					
11. Ağız dalaşımı başlatan biriyim.					
12. Güvenilir bir çalışmam.					
13. Gergin biriyim.					
14. Dahiyim, derin düşünürüm.					
15. Çok fazla hayranlık uyandırırım.					
16. Affedici bir doğaya sahibim.					
17. Düzensiz olma eğilimindeyim.					
18. Çok kaygılı biriyim.					
19. Aktif bir hayal gücüne sahibim.					
20. Sessiz olma eğilimindeyim.					
21. Genellikle güvenilir biriyim.					

22. Tembelliğe eğilimliyim.					
23. Duygusal olarak kararlı bir yapım vardır, kolayca üzülmeyen biriyim.					
24. İcat yapan biriyim.					
25. Girişken bir kişiliğe sahibim.					
26. Soğuk ve mesafeliyim.					
27. İşi bitirene kadar azimle çalışırım.					
28. Duygu durumu değişebilen biriyim.					
29. Sanatsal değerleri, estetik deneyimleri olan biriyim.					
30. Bazen utanır ve çekinirim.					
31. Hemen hemen herkese karşı nazik ve düşünceliyim.					
32. Her şeyi etkili yaparım.					
33. Gergin durumlarda sakin kalırım.					
34. Rutin işleri tercih ederim.					
35. İşlerimi planlar ve yaptığım planlara uyarım.					
36. Kolayca sinirlenirim.					
37. Fikir jimnastiği yaparım.					
38. Sanatsal ilgilerim azdır.					
39. Başkaları ile işbirliği yapmaktan hoşlanırım.					
40. Sanat, müzik ya da edebiyatla ilgilenen biriyim.					

Appendix G

Demographic Information Form

(In Turkish)

Demografik Bilgi Formu

Bu form demografik bilgiler ile ilgili sorular içermektedir. Yanıt belirtmek istemediğiniz soruları boş bırakabilirsiniz.

Yaşınız: _____

Cinsiyetiniz:

- Kadın Erkek Diğer

En son mezun olduğunuz okul:

- İlkokul
 İlköğretim (ilkokul ve ortaokul)
 Lise
 Ön Lisans
 Lisans
 Yüksek Lisans
 Doktora

Şu anda çalışıyor musunuz?

- Evet, tam zamanlı
 Evet, yarı zamanlı
 Hayır, öğrenciyim
 Hayır, iş bulamıyorum
 Hayır, çalışmayı tercih etmiyorum
 Diğer

Medeni Haliniz:

Bekar Evli Boşanmış Dul Diğer

Yaşamınızın büyük bölümünü nerede geçirdiniz?

Köy Kasaba Küçük Şehir Büyük Şehir Yurt dışı: _____

Şu anda nerede ikamet ediyorsunuz?

Şehir _____ Ülke _____

Anadiliniz:

Türkçe Diğer (lütfen belirtin): _____

Gelir düzeyiniz:

0 – 999

1000 – 1999

2000 – 2999

3000 – 3999

4000 – 4999

+ 5000

**ETİK KURUL DEĞERLENDİRME SONUCU/RESULT OF EVALUATION BY
THE ETHICS COMMITTEE**

(Bu bölüm İstanbul Bilgi Üniversitesi İnsan Araştırmaları Etik Kurul tarafından doldurulacaktır /This section to be completed by the Committee on Ethics in research on Humans)

Başvuru Sahibi / Applicant: Didem Topçu

Proje Başlığı / Project Title: Adaptation of the Guilt and Shame Proneness Scale to Turkish

Proje No. / Project Number: 2018-20024-125

1.	Herhangi bir değişikliğe gerek yoktur / There is no need for revision	XX
2.	Ret/ Application Rejected Reddin gerekçesi / Reason for Rejection	

Değerlendirme Tarihi / Date of Evaluation: 13 Aralık 2018

Kurul Başkanı / Committee Chair

Doç. Dr. İtir Erhart

Üye / Committee Member

Prof. Dr. Hale Bolak

Üye / Committee Member

Prof. Dr. Koray Akay

Üye / Committee Member

Prof. Dr. Ayhan Özgür Toy

Üye / Committee Member

Prof. Dr. Aslı Tunç

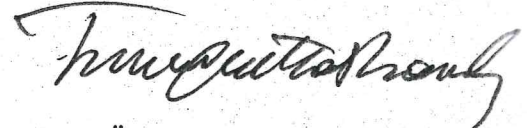
Üye / Committee Member

Prof. Dr. Turgut Tarhanlı

Üye / Committee Member

Prof. Dr. Ali Demirci